

## TS26C Sensing Edge



### Features

- Custom configurations
- Choice of colours
- Choice of housing materials
- Variety of mounting options
- Immediate activation
- Easy installation
- Fail-safe wiring available
- Durable construction
- Sealed switch compartment

TS26C is a compact and durable sensing edge which is ideal for a wide range of safety applications. Responding to both head-on and side impact, TS26C can be supplied in custom configurations to provide increased flexibility. The exterior housing is available in a choice of popular colours, housing materials and is supplied with either flat or angled aluminium channel to satisfy any mounting arrangement.

### Typical Applications:

- Moving doors
- Stage lifts
- Lift doors
- Side bumpers on AGV's

### Technical Specification

Actuating force (80mmØ test piece)	<140N (14.0kg)	
Overtravel movement to 250N	8mm	
Actuating distance (80mmØ test piece)	approx. 2mm	
Housing material/Colour	Black Black Red Yellow White	EPDM NBR *Special PVC Santoprene *Special EPDM *Special
Lead Times:	Black-EPDM Black-NBR Red Yellow White	Ex Stock *Special Ex Stock *Special *Special
Channel material	Flat - aluminium or plastic Angled - aluminium	
Ingress protection	IP65	
Operating temperature range	-20°C to + 50°C	
Typical weight	700g/m	
Recommended max voltage	30V d.c.	
Switching current @ 30Vdc	1A	

### Dimensions

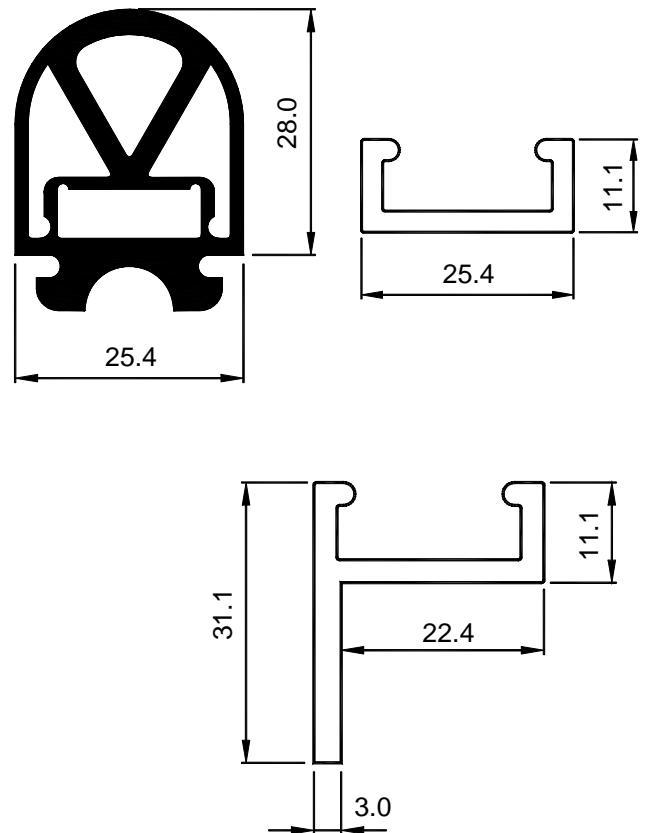

\* Special order—price by quotation—lead times may be up to 10 weeks.

GB 07/11

### Tapeswitch Ltd

Unit 38 Drumhead Road Chorley North Industrial Park Lancashire England PR6 7BX  
Tel: Int +44 (0) 1257 249777 Fax: Int +44 (0) 1257 246600 E-Mail: info@tapeswitch.co.uk