

**GUARDSCAN
GS140
LIGHT CURTAINS &
MULTI-BEAM SYSTEMS
TECHNICAL MANUAL 343361-00
English**

WARNING

Guardscan photo-electric safety systems are intended to protect operators working at or near dangerous machinery. They can only perform this function if they are correctly fitted to a suitable machine. It is essential that the full contents of this manual and all the authoritative documents referred to herein are fully understood before any attempt at installation is made. If in doubt contact your authorised Guardscan distributor.

IMPORTANT

This manual must accompany the product throughout its working life. Those persons responsible for the product must ensure that all persons involved in the installation, commissioning, operation, maintenance and servicing of the product have access to all the information supplied by the manufacturers of the machine and its safety system.

Guardscan Light Curtain Products are manufactured by:

Tapeswitch Ltd

Unit 38 Drumhead Road
Chorley North Industrial Park
Chorley
PR6 7BX
England

Tel : +44 (0) 1257 249777
Fax : +44 (0) 1257 246600
Email : info@tapeswitch.co.uk
Web : www.tapeswitch.co.uk

The Tapeswitch Group

Tapeswitch Corporation

100 Schmitt Boulevard
Farmingdale
New York
NY 11735
USA

Tel : +1 631 630 0442
Fax : +1 631 630 0454
E-mail : sales@tapeswitch.com
Web : www.tapeswitch.com

Tapeswitch Ltd (London Mat Industries)

635 Newbold Street
London
Ontario
Canada
N6E 2T8

Tel : +1 519 681 2980
Fax : +1 519 685 9318
Email : sales@londonmat.com
Web : www.londonmat.com

Tapeswitch GmbH

Postfach 10 20 23
Walter-Bruch-Straße 13
D-30982 Pattensen
Germany

Tel : +49 (0) 5101 14490
Fax : +49 (0) 5101 14499
Email : verkauf@tapeswitch.de
Web : www.tapeswitch.de

Tapeswitch Japan

5-11-23 Nakakasai - Hirano Bldg.
Edogawa-ku,
Tokyo
Japan 134-0083

Tel : + 81 3 5676 5421
Fax : + 81 3 5676 5422
Email : tsjapan@gc4.so-net.ne.jp
Web : www.tsjapan.co.jp

CONTENTS

1. GENERAL

2. SYSTEM DESCRIPTION

- 2.1 CURTAIN
- 2.2 INDICATORS

3. INSTALLATION

- 3.1 GENERAL
- 3.2 SEPARATION DISTANCE
- 3.3 ELECTRICAL INSTALLATION
- 3.4 INITIAL CHECKING AND ALIGNMENT

4. PERIODIC CHECKING, SERVICING AND MAINTENANCE

- 4.1 PERIODIC CHECKING
- 4.2 SERVICING
- 4.3 MAINTENANCE

5. TECHNICAL SPECIFICATION

- 5.1 GS140 LIGHT CURTAIN SYSTEM
- 5.2 ORDER CODES AND MODEL NUMBERS

1. GENERAL

Guardscan GS140 light curtains and grids are through-beam photo-electric machine guarding devices, designed to protect operators working at or near dangerous machinery, suitable for use in SIL 3 IEC/EN61508:2001, EN62061: 2005 & PL E ISO13849-1:2006 installations.

The GS140 light curtain system has been independently certified to EN 61496-1:2004.

When correctly installed on a suitable machine, the system will detect a person (or part of a person) entering a dangerous area in the vicinity of the machine and will cause dangerous motion to cease before that person can reach a position where injury could occur.

Guardscan GS140 light curtains and grids use infra-red technology. A curtain of infra-red light is projected across the dangerous area. Intrusion into this curtain by a person, or part of a person, will be detected by the system. This will cause safety output signals to be generated which will stop the dangerous motion of the machine.

GS140 systems are fully self-monitoring and meet worldwide requirements for safeguarding devices used on industrial machines.

WARNING

The information in this manual relates to the use of the GS140 light curtain, to provide a basic safety switching device.

In some applications a GS140 light curtain may be used together with other Guardscan equipment to provide additional functions and features. The additional information necessary for the correct use of a GS140 light curtain when used with other Guardscan equipment is provided with the equipment concerned.

In such cases, some installation parameters, notably the mounting position of the light curtain in relation to the dangerous parts of the machine, can be affected and close attention must be paid to all the information supplied with all equipment.

2. SYSTEM DESCRIPTION

2.1 CURTAIN

A GS140 system consists of an arrangement of infra-red emitting devices, which send out pulses of infra-red light (emitter), and an arrangement of infra-red receiving devices, which detect the pulses (receiver). Both arrangements are identical in shape and size, and are enclosed in a robust extruded aluminium section with aluminium end covers.

The emitter and receiver units together generate a curtain of infra-red light between them. This curtain is mounted in such a position in relation to the dangerous parts of a machine that a person or part of a person approaching those dangerous parts must first penetrate the curtain. This penetration is detected by the light curtain system and, by means of its output switching devices, the light curtain system causes the dangerous parts to go to a safe state (e.g. by stopping moving parts) before the person can reach

IMPORTANT

From the above it can be seen that safe use of a light curtain relies not only on the safety integrity of the curtain itself but also on its proper mechanical and electrical interfacing to the machine.

The safety integrity of the light curtain itself is the responsibility of Tapeswitch and the remainder of this section describes the features of the design by which safety integrity is ensured.

Proper mechanical and electrical interfacing is the responsibility of the user. Comprehensive information for this purpose is provided in section 3 of this manual.

2.1.1 GS140 BASIC SYSTEM

The curtain dimensions are defined by the detection zone height and the range (i.e. the distance between the sender and receiver units). The detection zone height must be selected to suit the application.

The detection zone of a light curtain (or Electrosensitive Protective Equipment) is defined in EN61496 as:

"The zone within which the specified test piece will be detected by the Electrosensitive Protective Equipment".

All the dimensions relating to the curtain, for each detection characteristic of a basic GS140 system, (or basic slave) are shown in Figure 1. The upper and lower boundaries of the curtain are indicated by arrows on the front window labels of each unit.

In the Blueview version of the GS140, the blue alignment beams are not an active part of the curtain. Nevertheless, the detection zone extends above and below them to the lines marked on the front window of the units.

See fig.2.

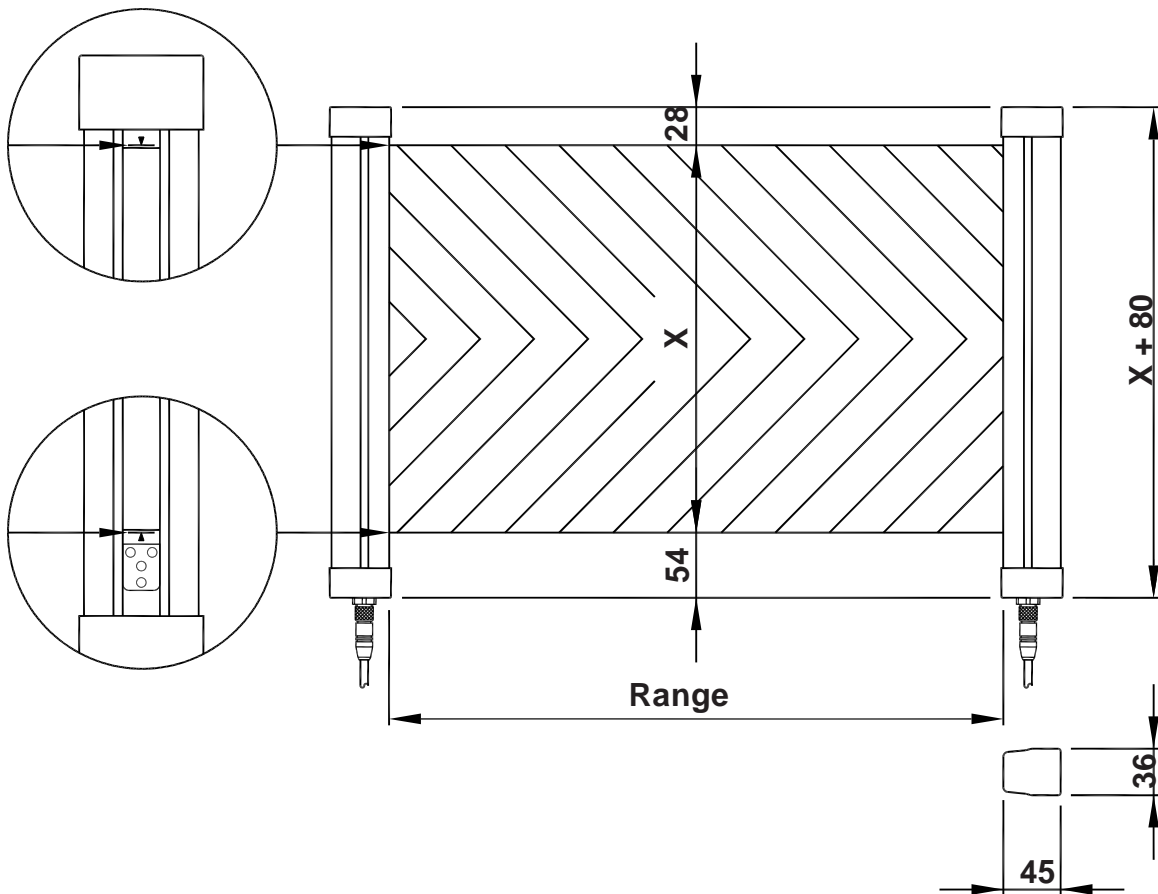

X = Nominal curtain length (e.g. 200, 400, 600 etc.)

Figure 1

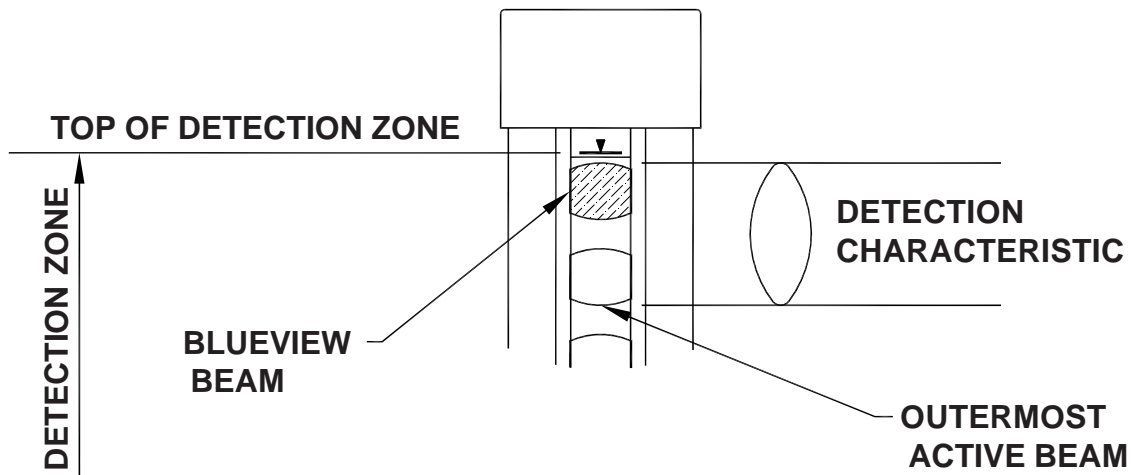

Figure 2

2.1.2 GS140 MULTI-BEAM SYSTEM

All the dimensions relating to the curtain, for each of the Multi-beam systems (or multi-beam slave systems) are shown in Figure 3. Each beam is fitted with Blueview alignment

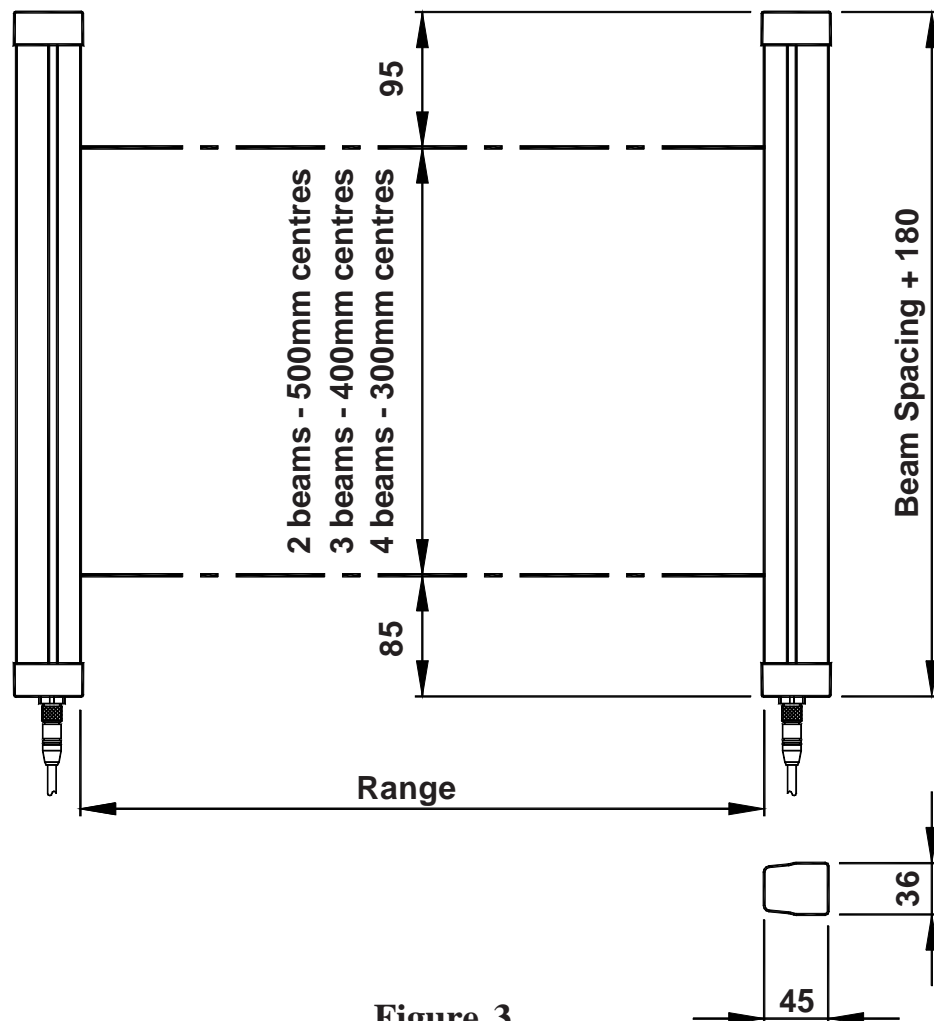

Figure 3

2.1.3 GS140 CASCADED SYSTEM

Additional flexibility to facilitate guarding in more than one plane is provided, by the capability to connect slave units to a basic or multi-beam master system.

The slave units can be basic, or multi-beam systems, with any of the defined detection characteristics of 14mm, 30mm, or 70mm.

The dimensions relating to the curtains, for each slave unit are as defined in the previous sections for each model. The upper and lower boundaries of each curtain are indicated by arrows on the front window labels of each unit.

A maximum of two slave units can be connected to a master system. Master and slave units can be assembled up to a maximum of 144 beams. Where:

- 14mm detection - 24 beams per 200mm curtain
- 30mm detection - 12 beams per 200mm curtain
- 70mm detection - 4 beams per 200mm curtain

Eg.
GS140/M/1000/30 + GS140/A/0400/70 = 68 beams

Note:

When master/slave columns have detection characteristics which have different range capabilities, these must be respected when systems are configured.

Important:

When master/slave columns have different detection capabilities the separation distance must be calculated and adhered to for each column separately.

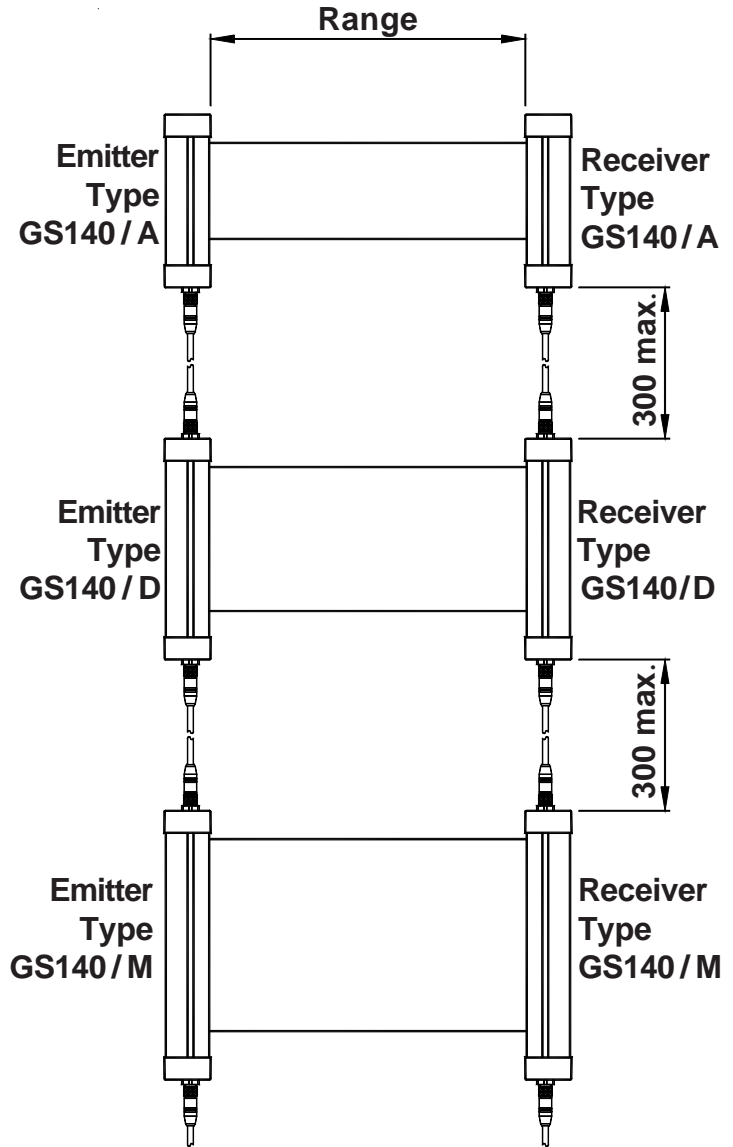

Figure 4

2.2 INDICATORS

2.2.1 LED OPTION

The standard/master receiver unit has four indicators as shown in Figure 5. The standard/master emitter unit has two indicators as shown in Figure 6. The slave emitter/receiver has one indicator as shown in Figure 7.

A description of each indicator is given in Table 1.

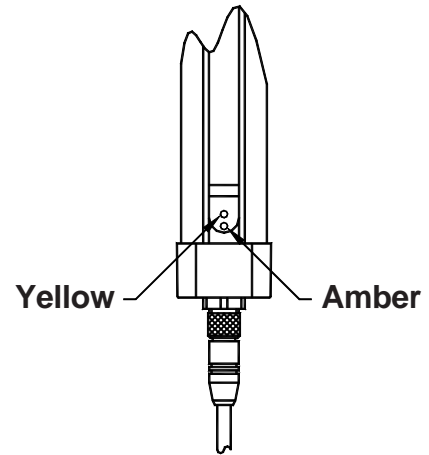

Figure 6

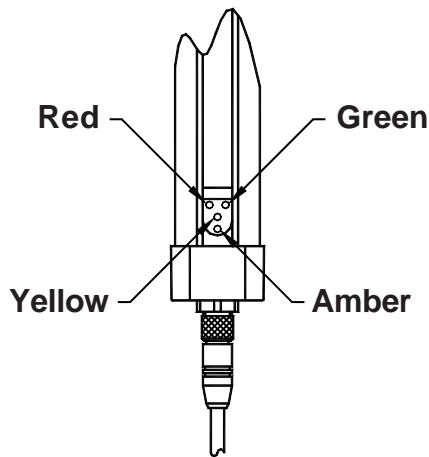

Figure 5

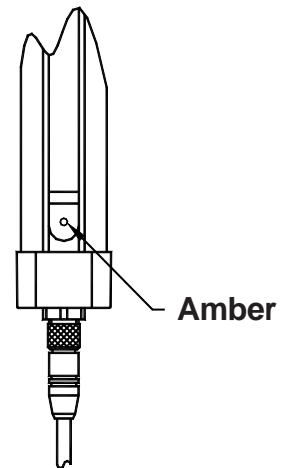

Figure 7

Unit	Colour	Description
Standard/ Master Emitter	Amber	Lit when power is connected to unit.
	Yellow	Lit steady when test input is applied. Lit flashing when emitter unit detects a problem.
Standard/ Master Receiver	Amber	Lit when power is connected to unit.
	Green	Lit when curtain is clear.
	Red	Lit when curtain is obstructed or when test input from emitter is applied.
	Yellow	Lit when receiver is in a blanking mode Lit flashing when receiver unit detects a problem.
Slave Emitter	Amber	Lit when power is connected to unit.
Slave Receiver	Amber	Lit when power is connected to unit.

Table 1

2.2.2 DIAG OPTION

The LED indicators on the standard/master emitter unit and all slave units are the same as for the previous section (2.2.1). The receiver unit contains a scrolling 4-digit alphanumeric display for diagnostic purposes as shown in Figure 8.

The various displays and their meanings are shown in Table 2 below.

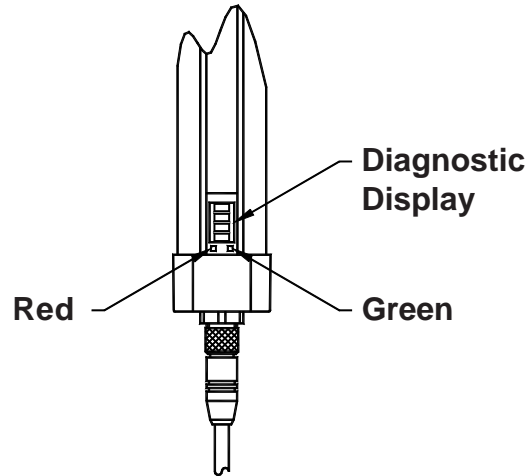

Figure 8

Displays in normal operation		
Display	Mode	Description
Scrolls CURTAIN OK	No Blanking	The curtain is clear and operating correctly
Scrolls "Mode" OK	Blanking	
Bxxxx	No Blanking	The curtain is obstructed and beam number xxx is the first beam in an incorrect state
Scrolls "Mode" Bxxx	Blanking	

Displays with faults with external causes		
Display	Mode	Description
SYNC	No Blanking	Unable to synchronise with the Emitter column
Scrolls "Mode" SYNC	Blanking	
LOCKOUT CHANNEL A O/P HIGH		A short circuit from Output A to +24Vdc
LOCKOUT CHANNEL A O/PLOW		A short circuit from Output A to 0Vdc
LOCKOUT CHANNEL B O/P HIGH		A short circuit from Output B to +24Vdc
LOCKOUT CHANNEL B O/P LOW		A short circuit from Output B to 0Vdc

Internal Faults	
Display	Description
LOCKOUT CHANNEL X FAULT	Fault not serviceable in the field. Return to vendor for repair.

Table 2

3. INSTALLATION

3.1 GENERAL

WARNING

Guardscan GS140 systems are designed to protect operators working at or near dangerous machinery. They can only perform this function if they are correctly fitted and interfaced to a suitable machine. Those persons responsible for the machine must ensure that all persons involved in the installation of the photo-electric safety system have the necessary knowledge, training and experience and that they are fully aware of all laws, rules, regulations and codes of practice pertaining to their task.

EN999 gives guidance on the dimensions and positioning of photo-electric safety devices fitted to industrial machines. The main considerations are described below.

The attention of the installer is drawn to following general requirements for the installation of a GS140 system:

(a) The dangerous motion of the machine must be electrically controllable.

(b) The machine response/stopping performance must be adequate and consistent.

(c) It must be possible to stop the dangerous motion of the machine at any point in its operation, in any operating mode.

(d) The control system as a whole must be designed and constructed to provide the appropriate safety integrity level (SIL) as defined in EN62061-1:2005 'Safety of machinery-Functional safety of safety-related electrical, electronic and programmable electronic control systems'. The appropriate SIL should be as prescribed in the relevant C type EN standard for the type of machine concerned. In the absence of such a standard the appropriate SIL should be determined by performing a risk assessment as described

in ISO EN14121-1:2007 'Safety of machinery: Risk assessment principles'.

(e) At power on, or after a power interruption, it must not be possible for the machine to start until a manual control has been operated. This is known as 'start interlock'. The basic GS140 does **not** provide this function. The function of the basic GS140 system is 'GUARD ONLY' i.e. when the curtain is clear the outputs are ON and when the curtain is broken the outputs are OFF.

(f) After the curtain has been actuated it must not be possible for the machine to restart until a manual control has been operated. This is known as 'start/restart interlock'. The basic GS140 does **not** provide this function. The function of the basic GS140 system is 'GUARD ONLY' i.e. when the curtain is clear the outputs are ON and when the curtain is broken the outputs are OFF.

(g) Steps must be taken to prevent access to the dangerous parts of the machine from any direction not covered by the photo-electric curtain. Such steps could include fixed or interlocking fences or screens, additional photo-electric devices or pressure sensitive mats. Similar steps should be taken to prevent a person standing between the curtain and the dangerous parts.

3.1.1 MOUNTING BRACKET OPTIONS

(h) The correct minimum separation distance must be observed. The curtain must be mounted in the correct position in relation to the dangerous parts of the machine to take account of the stopping performance of the machine, the curtain format used and the detection capability of the curtain.

(i) The curtain must be of sufficient height such that access to the dangerous parts, from the direction of approach of the operator, is only possible by obstructing the curtain taking into account all possible operator positions.

(j) No devices other than those specified in this manual should be connected to the internally generated power supply of the system.

(k) After installation the machine/guard system must be commissioned in accordance with the requirements of section 4.1.1 of this manual.

(l) Any covers removed during installation must be replaced as soon as possible.

There are 3 types of mounting bracket options available for the GS140 Systems:

3.1.1.1 MOUNTING BRACKET TYPE AB

The adjustable mounting bracket - Type AB combines a robust design with quick release facility, the adjustable bracket promotes speedy installation and also allows for easy interchange of a light curtain unit without the need for re-alignment. This option is specified as 'AB' in the order code.

3.1.1.2 MOUNTING BRACKET TYPE CB

The Clamp Bracket - Type CB offers a neat and compact design to provide versatile installation. In addition, the Clamp Bracket Mounting Plate has been specially designed to allow angular adjustment of the light curtain. This option is specified as 'CB' in the order code.

3.1.1.3 MOUNTING BRACKET TYPE EB

The Endcap Bracket - Type EB is designed to be used in situations where space is limited, the slimline nature of the Endcap Bracket allows the light curtain to be easily mounted in a confined space such as on the external edge of a fixed structure or adjacent to a floor post. This option is specified as 'EB' in the order code.

For installation instructions regarding these mounting bracket options please see the installation sheets supplied with each kit.

3.1.2 OPTICAL ALIGNMENT

The emitter and receiver units should be mounted facing each other at the same height with their axes aligned. Misalignments as illustrated in Figure 8 should be avoided.

The GS140 Blueview light curtain incorporates the Blueview alignment-aid system. This works on the principle of making it easy to establish the actual axis of the invisible infra-red curtain by looking at visible blue beams that are shining through the same block of lenses as the infra-red beams. The system has blue beams at the top and bottom of both the emitter unit the receiver unit.

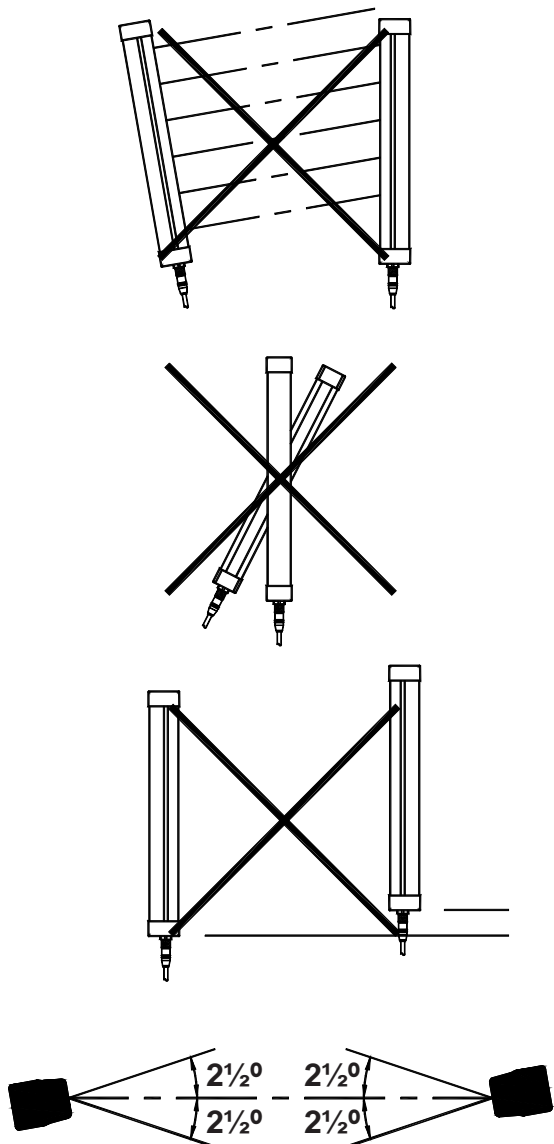

Figure 8

3.1.3 REFLECTIVE SURFACES

There should be no reflective surfaces within the 'field of view' of the curtain units. Reflective surfaces within the field of view can lead to non-detection of an obstruction. The field of view of each of the emitter and receiver units is approximately 2½ degrees either side of the optical axis.

A minimum distance from the optical axis to any reflective surface must be observed. This distance depends on the actual operating distance and must take into account possible misalignment. This is illustrated in Figure 9. The distance should be determined as follows:

Operating distance $L < 3m$: $X > 130mm$

Operating distance $L > 3m$: $X > 0.0437Lmm$

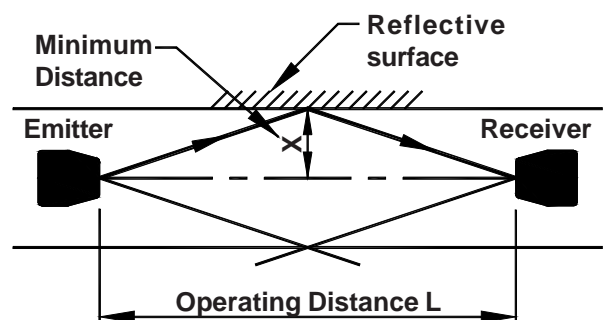

Figure 9

3.1.4 SYSTEMS IN CLOSE PROXIMITY

In order to avoid nuisance interference between adjacent systems, whenever two sensing units are used within each other's sensing range, ensure that the front window of any unit is not within the field of view of units of the opposite type from other systems.

This can be achieved by ensuring that units of the same type are mounted facing in opposite directions. See Figure 10.

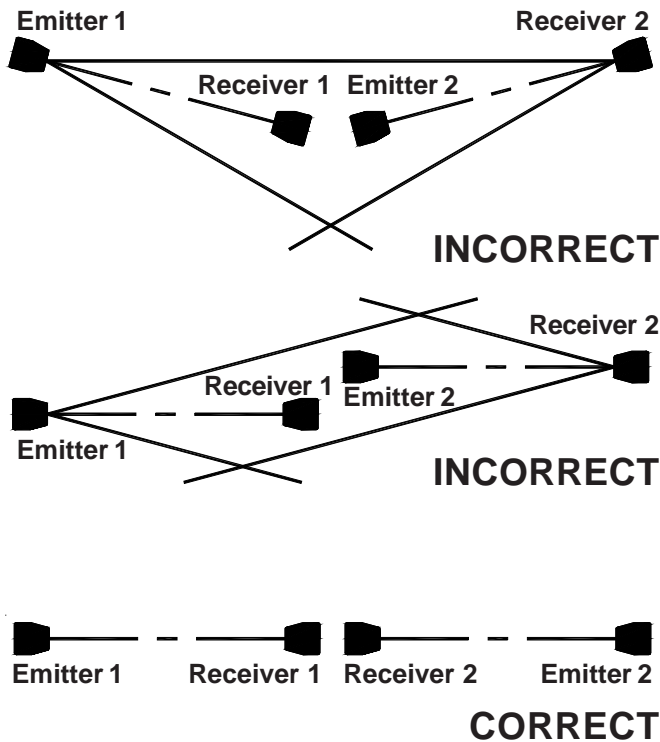

Figure 10

3.2 SEPARATION DISTANCE

Any machine, regardless of the efficiency of its braking system, will take a certain time to come to rest after a stop signal is generated.

The time from the instant that the curtain is broken to the instant that dangerous motion actually ceases is called the overall system response time. The dangerous parts will obviously continue to move during this time. The curtain must therefore be positioned at a certain minimum distance from the dangerous parts to prevent a person who has obstructed the curtain from reaching the dangerous parts before they have stopped.

This distance is the minimum separation distance and is defined as the distance, in the direction of approach, between the physical point at which the curtain detects an obstruction and the nearest dangerous parts.

EN999 provides guidelines on how to determine the minimum separation distance for a given application.

Figure 11 provides a methodology for determining the separation distance of a GS140 system, which is as follows:

- (a) Identify the hazards and assess the risks (see ISO EN12100-1:2003 and ISO EN14121-1:2007).
- (b) If a type C standard exists for the machine, use the distance specified by that standard.
- (c) If there is no type C standard, or if the C standard does not specify a minimum distance, then use the formulae in EN999 (reproduced in the following sections) to calculate the separation distance.
- (d) Incorporate the distance in the machine design.
- (e) Ensure that the device has been installed in such a manner that access to the danger zone is not possible without detection.
- (f) If the positioning of the curtain allows persons to be in a position between the curtain and the danger zone, supplementary measures may be required depending on the risk.

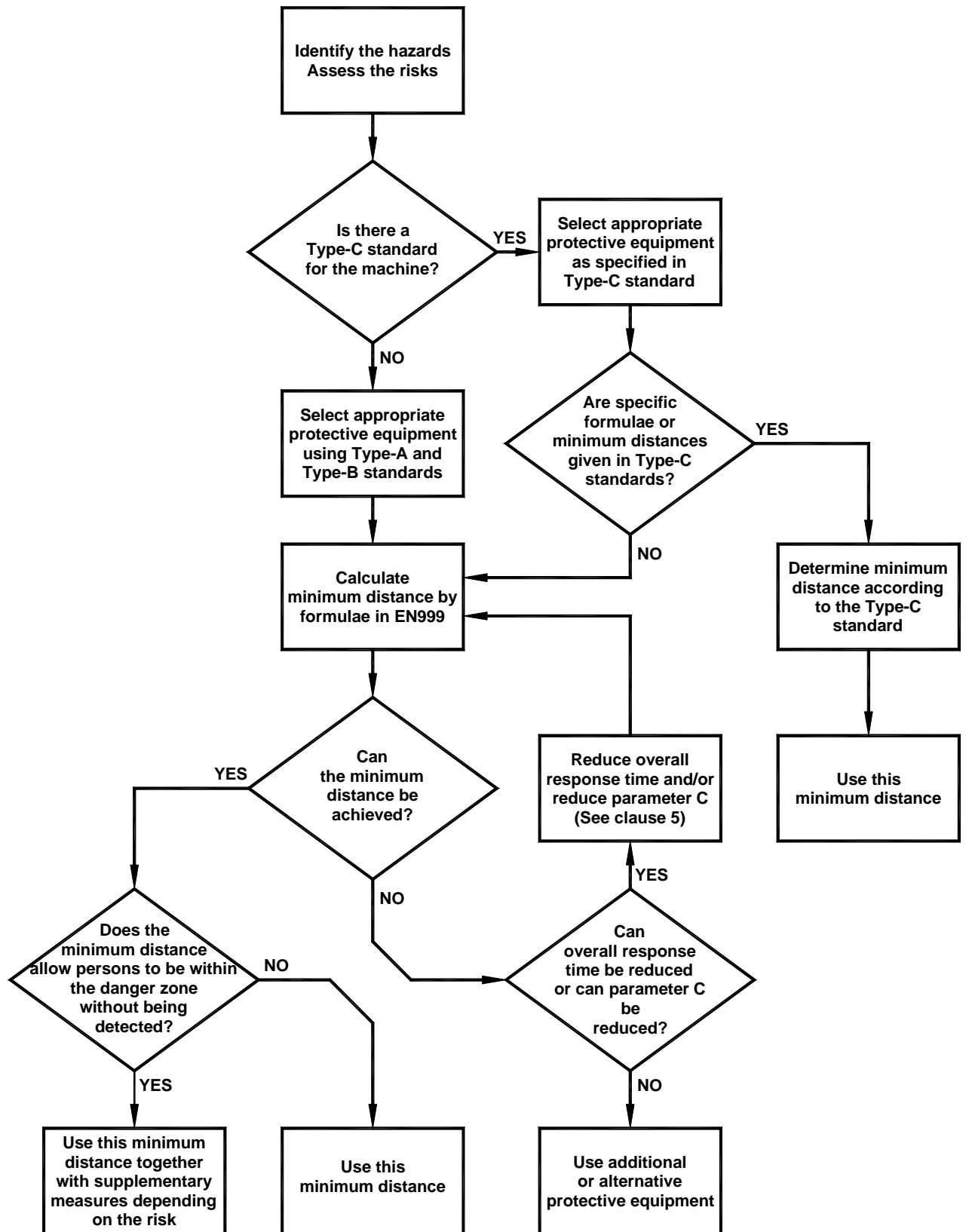

Figure 11

3.2.1 GS140 SYSTEMS

The separation distance depends on the application and the following factors:

- the curtain format used.
- the detection capability, d .
- the overall system response time, T .
- the curtain penetration figure, C .
- the derived body part speed, K .

The overall system response time, T , is a period, in seconds, given by the sum of the response times of the safety device and the machine control system. The response time of the GS140 system is 18ms in all cases. The response time of the machine control system should be measured using a suitable device and the highest value recorded, plus a suitable allowance for brake deterioration, should be used in the calculation of the minimum separation distance. It is recommended that the overall system response time is recorded on the machine information label or plate.

The curtain penetration figure, C , is a distance, in millimetres, representing the distance by which part of a person penetrates the plane of detection of the safety device before actuation of the sensing unit occurs. This figure is a function of the detection capability.

The derived body part speed, K , is a speed, in millimetres per second, derived from measurement data of speeds of movement of various parts of the human body. This figure represents the derived speed of that part of the body which will obstruct the sensing unit.

The minimum separation distance should be recorded on the machine information label or plate.

The general formula for calculating the minimum separation distance, S , in millimetres, for GS140 light curtains used is as follows:

$$S = K \times T + C$$

3.2.1.1 NORMAL APPROACH

Normal approach format is shown in Figure 11. For normal approach format the inner edge of the front window of each unit (i.e. the edge which is nearest to the machine) should be considered to be the point at which an obstruction is detected. See plane X in Figure 12.

(a) For a normal approach application where the curtain has a detection capability, d , of $\leq 40\text{mm}$:

$$S = K \times T + C$$

where $K=2000$ and
 $C=8(d-14)$, but not less than 0;

If this formula gives S greater than 500mm then S can be recalculated $K = 1600$ but in this case S must not be less than 500mm.

If it is foreseeable that the guard will be used in a non-industrial environment, eg, in the presence of children, the minimum distance shall be increased by at least 75mm and a body part speed of 2000mm/s must be used.

(b) For detection capability, d, of 30mm:

(c) For detection capability, d, of 70mm
(when d is greater than 40, C=850):

$$S = K \times T + C$$

$$S = K \times T + C$$

where $K=2000$ and
 $C=8(d-14)$

where $K=1600$ and
 $C= 850$

i.e. $S = (2000 \times T) + 128$

i.e. $S = (1600 \times T) + 850$

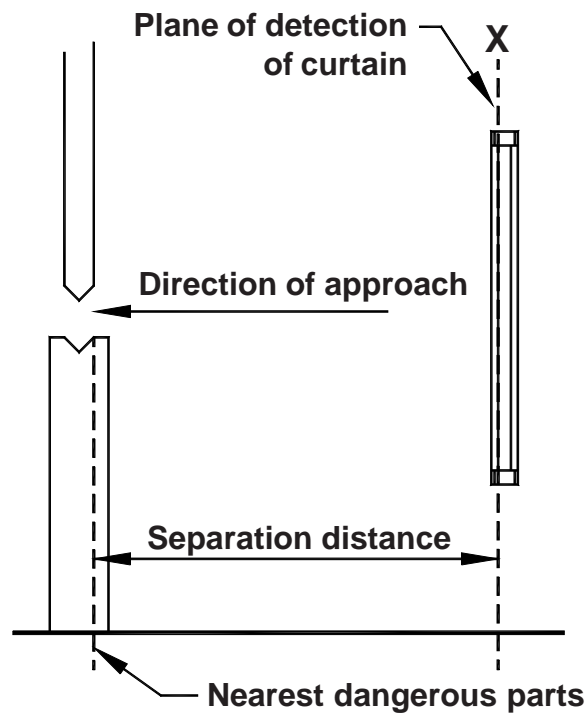

Figure 12

3.2.1.2 PARALLEL APPROACH

Parallel approach format is shown in Figure 12. For parallel approach format the outer curtain detection limit (as shown on the front window of each unit) minus the detection capability, should be considered to be the point at which an obstruction is detected. See Plane X in Figure 13.

$$S = K \times T + C$$

where $K = 1600 \text{ mm/s}$
 $C = 1200\text{mm} - 0.4H$, but not less than 850mm, where H is the height of the detection zone above the reference plane, in mm.

i.e. $S = (1600 \times T) + 1200 - 0.4 \times H$

For this type of protective equipment, the height H of the detection zone shall not exceed 1000mm. If H is greater than 300mm (200mm for non-industrial applications), the risk of undetected access beneath the detection zone shall be considered.

The lowest allowable height of the detection zone shall be calculated using the formula:

$$H = 15(d - 50\text{mm}).$$

Therefore, for a given height of the detection zone, the detection capability, d, is:

$$d = H/15 + 50\text{mm}$$

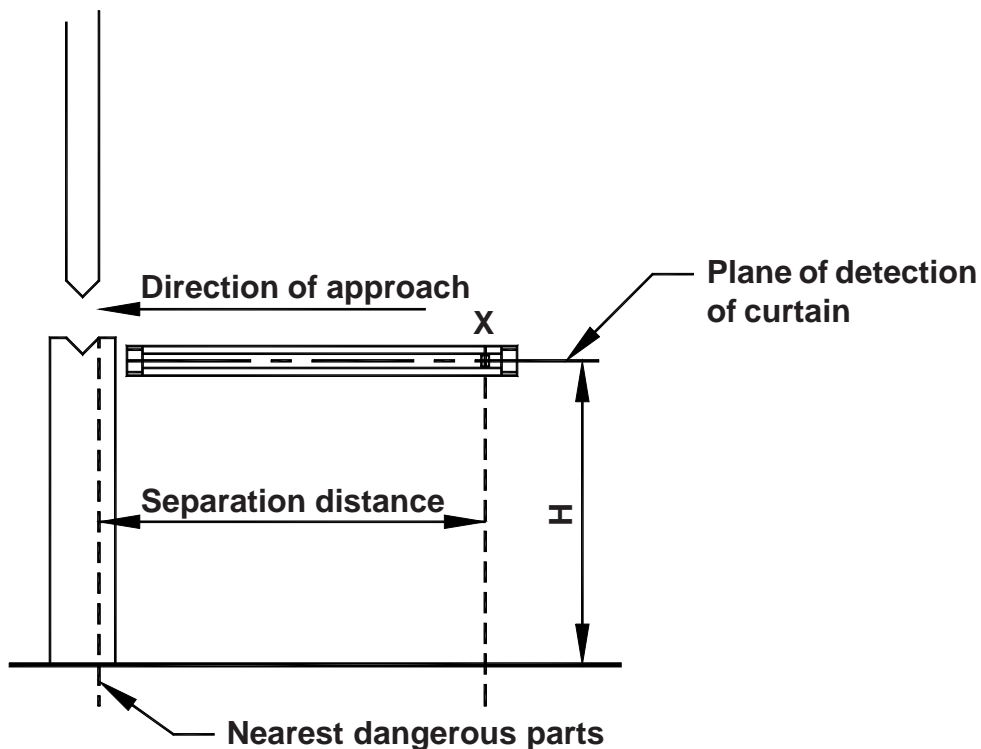

Figure 13

3.2.1.3 ANGLED APPROACH

If it is necessary to install the curtain, at an angle to the direction of approach as shown in Figure 14, then the following requirements apply:

An angle within $\pm 5^\circ$ of normal or horizontal, need not be considered to be angled, and the relevant formula used.

For detection zones which are positioned at angles greater than $\pm 5^\circ$, to the direction of approach, account shall be taken of the risks associated with the direction of approach, and the most appropriate formula used.

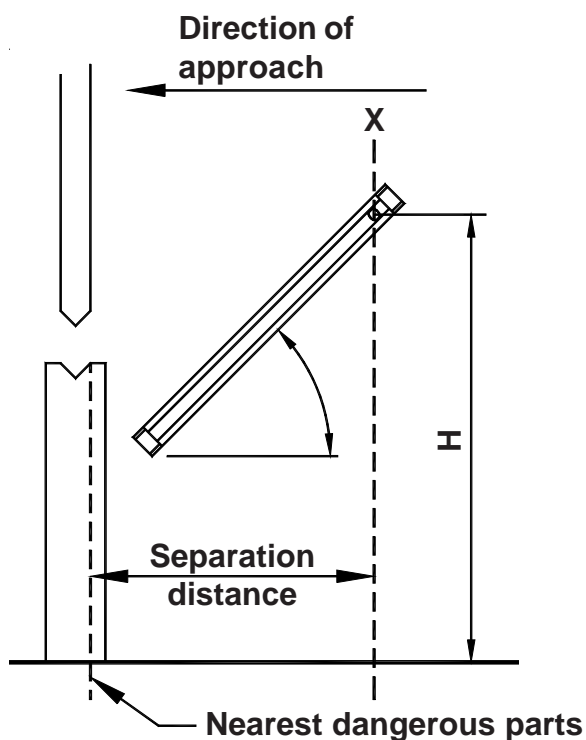

Figure 14

3.2.1.4 APPROACH TO 'L' INSTALLATION

The GS140 system using a master - slave combination as shown in Figure 15, can provide dual axis guarding, giving both trip and presence sensing capability.

The two formulae for normal and parallel approach must be used together.

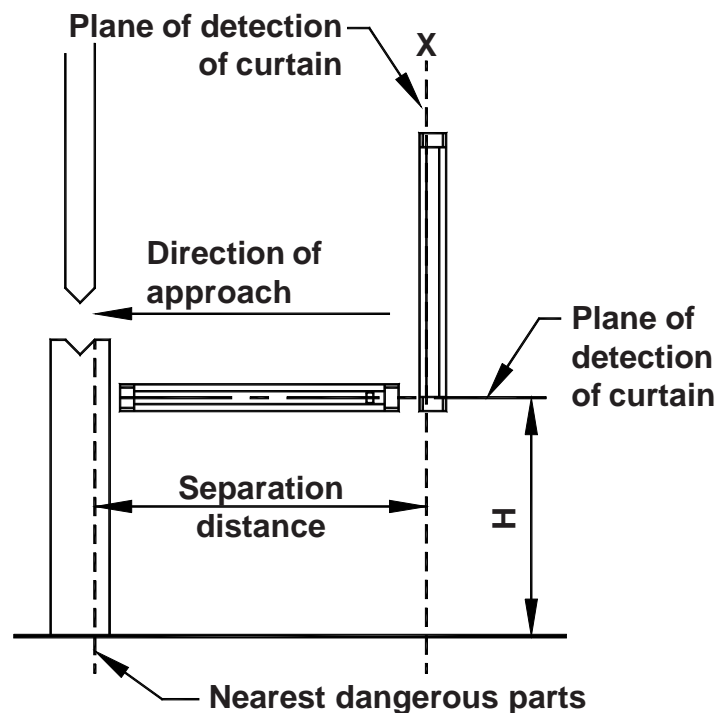

Figure 15

3.2.1.5 POSITIONING OF GS140

EN999 gives guidance on the dimensions and positioning of photo-electric safety devices fitted to industrial machines. The main considerations are described below and are illustrated in figure 16.

(a) The appropriate detection zone height must be selected. The curtain must be of sufficient height such that access to the dangerous parts, from the direction of approach of the operator, is only possible by obstructing the curtain taking into account all possible operator positions.

(b) The correct minimum separation distance must be observed. The curtain must be mounted in the correct position in relation to the dangerous parts of the machine to take

account of the stopping performance of the machine, the curtain format used and the detection capability of the curtain.

(c) Steps must be taken to prevent access to the dangerous parts from any direction not covered by the curtain and prevent an operator from standing between the curtain and the dangerous parts without obstructing the curtain. Additional mechanical guarding will usually be necessary to achieve this.

The physical parameters affecting the positioning are the dimensions of the detection zone of the light curtain (i.e. the detection zone height and the range) and the minimum separation distance. These are described in the following sections.

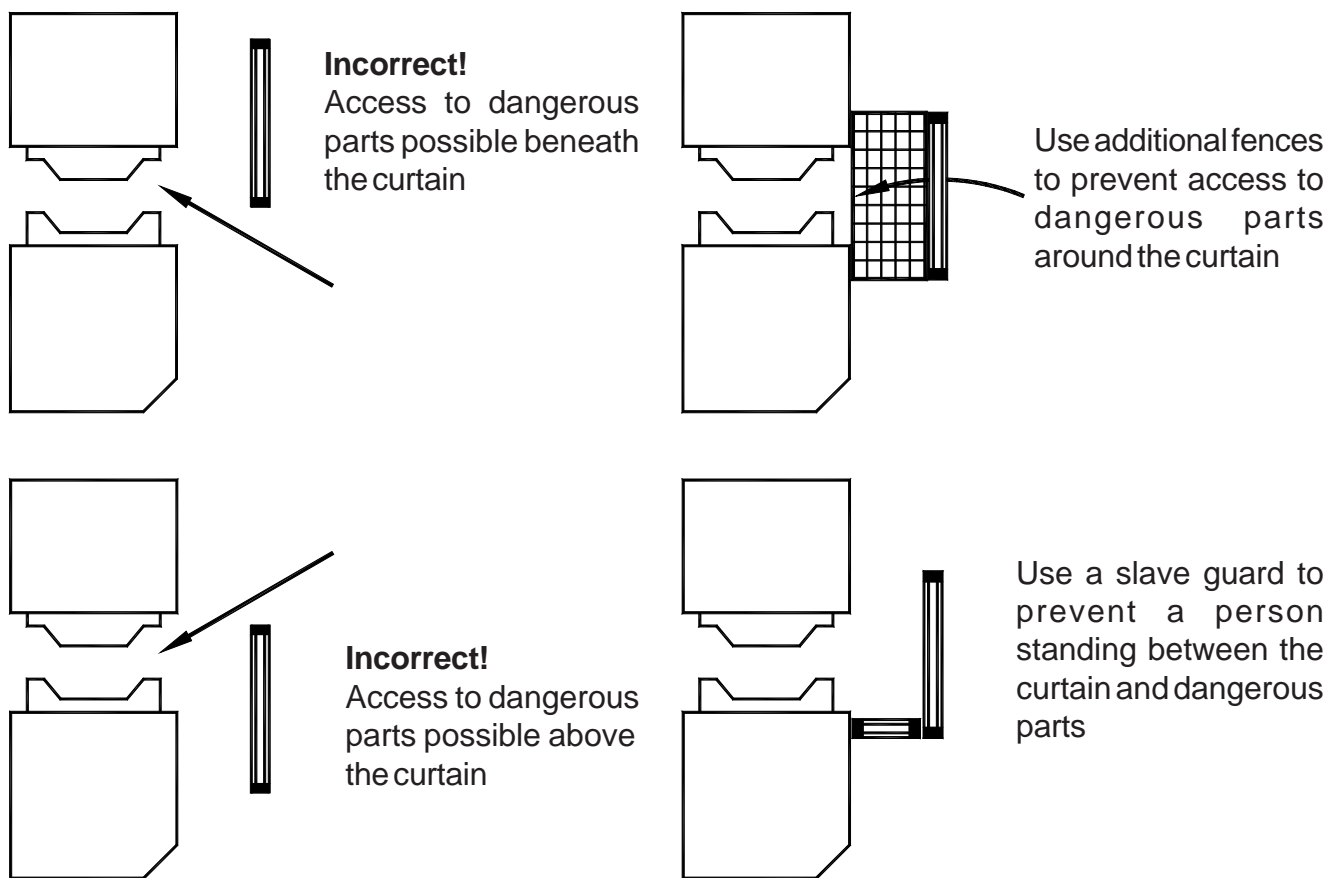

Figure 16

3.2.2 GS140 MULTI-BEAM SYSTEM

The separation distance depends on the application and the following factors:

- the curtain format used.
- the overall system response time, T.

The overall system response time, T, is a period, in seconds, given by the sum of the response times of the safety device and the machine control system. The response time of the GS140 system is 20ms in all cases. The response time of the machine control system should be measured using a suitable device and the highest value recorded, plus a suitable allowance for brake deterioration, should be used in the calculation of the minimum separation distance. It is recommended that the overall system response time is recorded on the machine information label or plate.

The minimum separation distance should be recorded on the machine information label or plate.

The calculations for minimum separation distance, S, in millimetres, for GS140 Multi-beam light curtains used in normal format are as follows:

$$S = (1600\text{mm/s} \times T) + 850\text{mm}$$

the system has to be mounted with the bottom beam set at a height from the floor as shown:

GS140/2:	400mm
GS140/3:	300mm
GS140/4:	300mm

3.2.3 MULTI-SIDED GUARDING

By using mirror columns the beams can be deflected around corners to form two and three sided guard configurations. It should be borne in mind that for each mirror used the range is reduced by approximately 20%. Also the alignment of systems with mirrors can be difficult especially where the mounting surfaces are uneven. It is therefore recommended that no more than two mirrors are used between any pair of emitter and receiver units. See Figures 17, 18 and 19.

Note: The arrangement shown in Figure 19 is not recommended, as it is very difficult to determine that the safety distance S is correct.

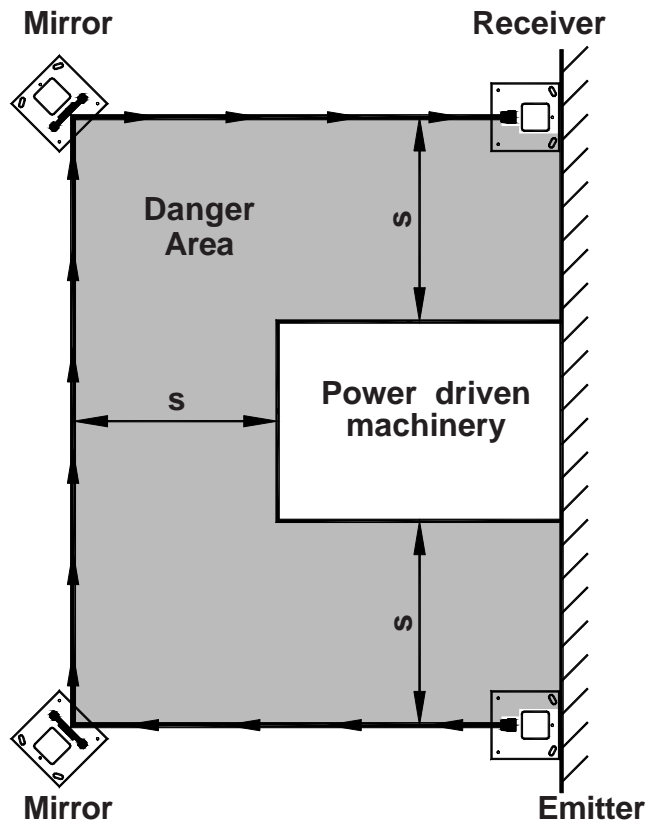
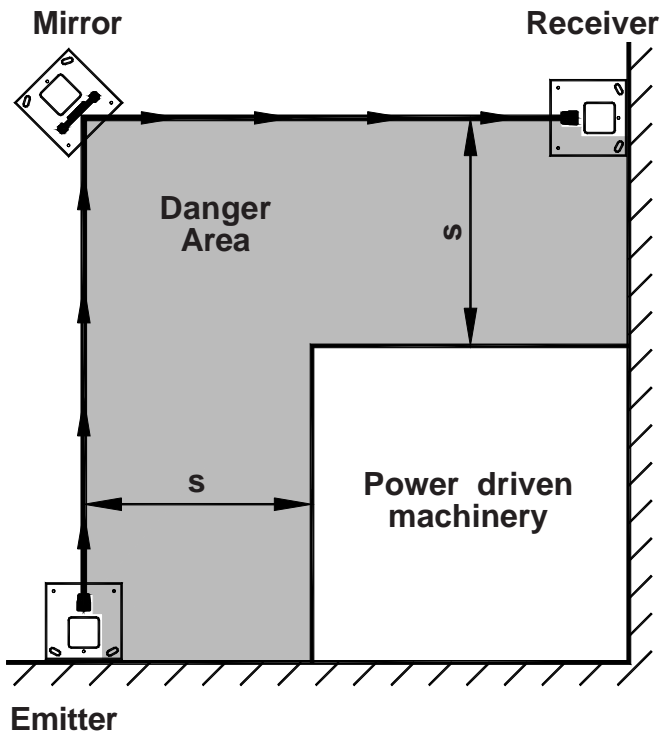

Figure 17 - Guarding a two sided area

Figure 18 - Guarding a three sided area

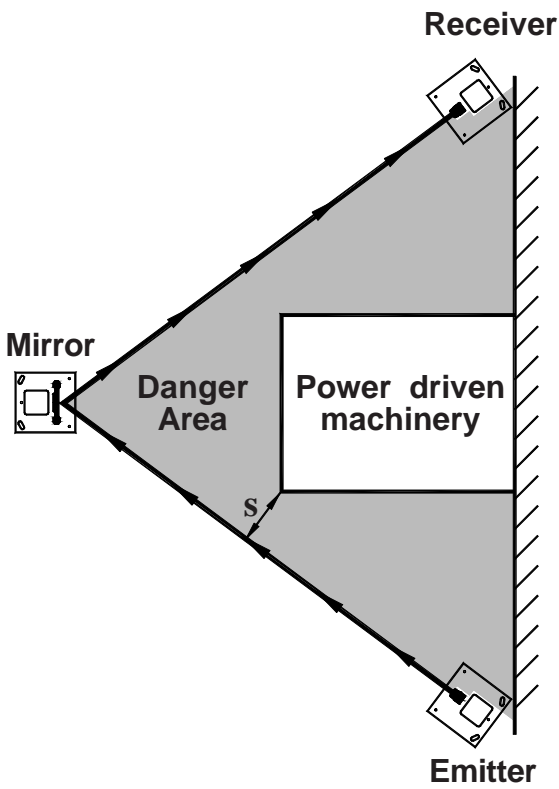

Figure 19 - Incorrect use of two sided guarding

3.3 ELECTRICAL INSTALLATION

3.3.2 EMITTER UNIT

3.3.1 GENERAL

Both units must be supplied with 24V d.c. $\pm 20\%$. This d.c. supply must be an isolated supply from a safety transformer which meets the requirements of IEC60742 and which can maintain a minimum of 18V d.c. output during a 20ms dip in the mains supply. The -ve side of this supply should be earthed, and the cables should be routed separate from power/motor drives.

IMPORTANT

Power should be applied to both units at the same time. If power is removed from the emitter unit, power must also be removed from the receiver unit at source. Failure to do so may result in the units failing to communicate and appearing to be faulty. The screen is to be connected to the system PE in the control cabinet.

If the moulded connection cable is to be extended, screened cable is to be used with a minimum wire cross sectional area of 0,5mm². Care must be taken to ensure that the continuity and protection provided by the screen is maintained.

The power consumption is dependant on the detection zone height of the system but is less than 12VA.

3.3.2.1 GENERAL

The emitter unit uses five terminals, two for the d.c. supply, two for the test input (see 3.3.2.2) and one for the protective earth, as shown in Figure 20.

3.3.2.2 TEST INPUT

On some machines a test input is used to check the interface between the photo-electric safety device and the machine. The input simulates the obstruction of the curtain in order to cycle the output relays and thereby expose any fault before the next machine cycle. This input is applied during a safe part of the machine cycle or at the end of the cycle.

If this function is used a normally closed contact should be connected as shown in Figure 20.

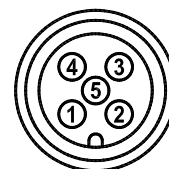
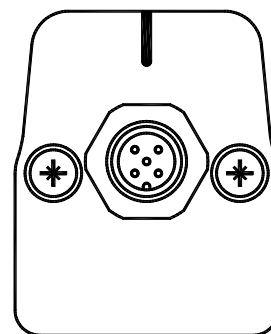

- 1: Brown / BN = +24V
 - 2: White / WH = 0V
 - 3: Blue / BU = } TEST OR
 - 4: Black / BK = } Link OR
 - 5: Grey / GY = Protective Earth
- Normally closed contact

Figure 20

3.3.3.2 SAFETY OUTPUTS

This contact must open for a minimum of 35ms. When this contact is opened the light curtain safety outputs will be switched off and will remain off until the test contact closes again and the curtain self-tests have been successfully performed (assuming that the curtain is not obstructed).

From re-closing of the test contact, the safety outputs will switch on again after 100ms. The continuous current through the test contact is 11mA.

If test input is not used then these terminals should be linked together.

3.3.3 RECEIVER UNIT

3.3.3.1 GENERAL

The receiver unit uses eight terminals, two for the d.c. supply, two for safety outputs (see 3.3.3.2), and one for protective earth, as shown in Figure 21.

The 24Vdc supply must have a 2A quick blow in-line fuse fitted.

The two output signal switching devices (OSSDs) should be wired to independent switching devices in the machine control circuit. The OSSDs are solid state devices and are actively monitored and short circuit protected.

The maximum current is 0.2A.

The output voltage, U_A , of each OSSD is dependent on the supply, U_V , and the load which is given by the following expression:

$$U_A > U_V - 2V$$

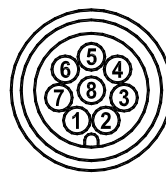
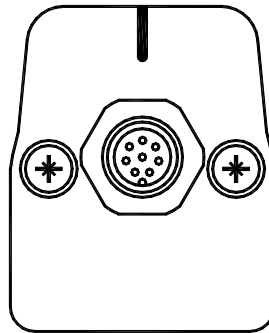

- 1: White / WH = 0V
- 2: Brown / BN = +24V (Note: Must be fused 2A - Quick Blow)
- 3: Green / GN = Protective Earth
- 4: Yellow / YE = _____
- 5: Grey / GY = _____
- 6: Pink / PK = } Serial Port
- 7: Blue / BU = }
- 8: Red / RD = Not Used

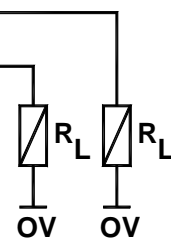

Figure 21

3.3.3.3 SERIAL COMMUNICATIONS

This interface is used only when blanking is used. If blanking is not used then these two terminals should be left unconnected.

In order to use blanking a separate programming unit is required. This unit needs to be connected to the receiver unit when setting up the blanking function. This is illustrated in Figure 22.

No equipment other than specified Guardscan equipment should be connected to the serial interface terminals

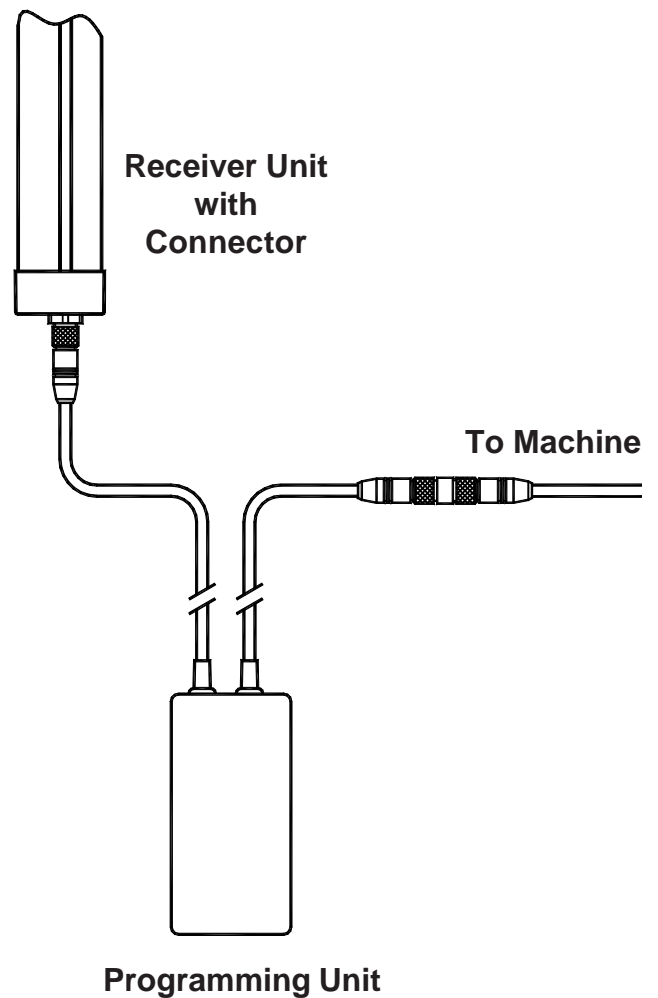

Figure 22

3.3.4 INTERFACING TO A MACHINE

The interfacing of a light curtain to a machine can be achieved using discrete components but usually it is achieved by means of an interface unit such as the Guardscan SRUS

All the relays shown are safety relays with positively guided contacts. If this circuit is implemented using discrete components it is essential that this type of relay is used.

The circuit diagram for the SRUS and the typical connections to the supply, the GS140 light curtain and the machine are shown in Figure 23 below.

Full details of the SRUS interface unit is available separately from your Guardscan distributor.

IMPORTANT

A number of manufacturers produce units containing circuits of this type. Care should be taken to ensure that the inputs of these units can accept the PNP outputs of the light curtain. The GS140 system checks that its outputs are functioning correctly by switching them off for 100 microseconds every scan.

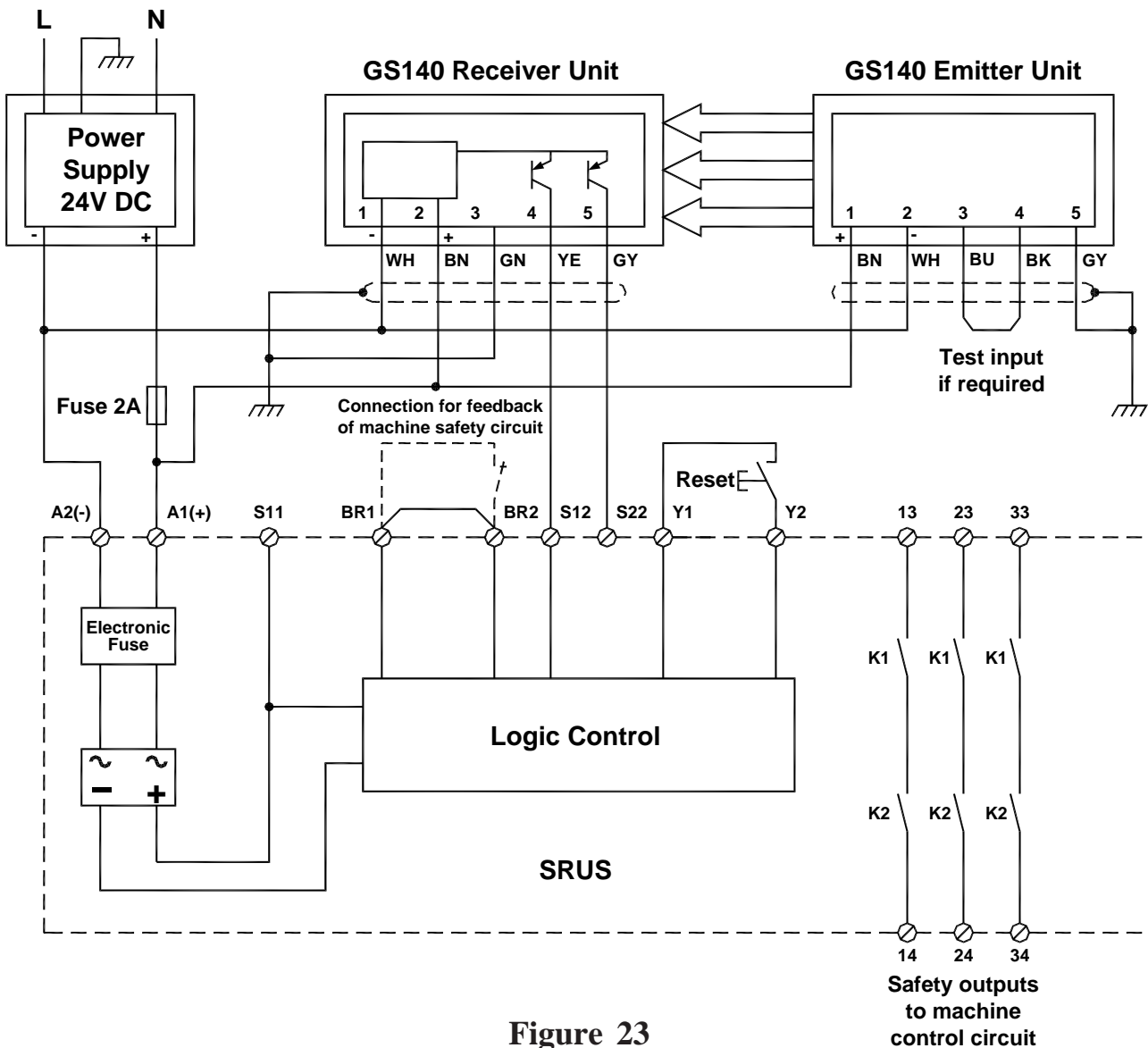

Figure 23

3.4 INITIAL CHECKING AND ALIGNMENT

The procedure for alignment is described below.

3.4.1 GENERAL

Apply power to the GS140 system.

IMPORTANT

Power should be applied to both units at the same time. If power is removed from the emitter unit, power must also be removed from the receiver unit at source. Failure to do so may result in the units failing to communicate and appearing to be faulty. The screen is to be connected to the system PE in the control cabinet.

The amber indicators on the emitter and the receiver units should be lit. If either of the indicators are not lit, check the wiring.

The yellow indicators on the emitter and the receiver units should be in the off state. If either of these two indicators are flashing there is a fault, contact your Guardscan distributor. If the yellow indicator on the emitter unit is on constantly, check the wiring as described in section 3.3.2

The green indicator on the receiver unit should be lit, if not, adjust the units into general alignment until the green indicator comes on.

3.4.2 GS140 SYSTEM

Adjust the units to optimum alignment as follows:

1. Slowly turn the emitter unit clockwise until the green indicator on the receiver unit goes off and the red indicator comes on. Note this position.
2. Then turn the emitter unit anti-clockwise, again until the green indicator goes off and the red indicator comes on. Note this position.
3. Fix the emitter unit at the centre of the two noted positions.
4. Repeat steps 1, 2 and 3 but this time turning the receiver unit.

3.4.2 GS140 BLUEVIEW SYSTEM

The GS140 Blueview light curtain incorporates the Blueview alignment-aid system. This works on the principle of making it easy to establish the actual axis of the invisible infra-red curtain by looking at visible blue beams that are shining through the same block of lenses as the infra-red beams. The system has blue beams at the top and bottom of both the emitter unit the receiver unit.

Adjust the units to optimum alignment as follows:

1. Align the units so they appear to be pointing at each other.
2. Stand at the receiver unit and look back at the emitter unit. By moving your head around, find the position where the top Blueview beam appears the brightest.

This is the current actual axis along which the top of the emitter curtain is pointing.

3. Estimate by how much the emitter unit would need to be rotated/tilted (up or down, left or right) so the emitter top Blueview beam would appear brightest when viewed directly in front of the receiver top Blueview beam.

4. Adjust the emitter unit to the alignment estimated.

5. Repeat steps 3 and 4 until the emitter top Blueview beam is aligned with the receiver top Blueview beam.

6. Repeat steps 2, 3 and 4 for the emitter bottom Blueview beam.

7. Beginning by standing at the emitter unit and looking back at the receiver unit, repeat the procedure to align the receiver top and bottom Blueview beams.

Using the test piece provided, obstruct the curtain. On the receiver unit the green indicator should go off and the red indicator come on. Move the test piece in and out of the curtain several times and check that the indicators change state appropriately each time.

See section 4.2 of this manual if the system does not function as described above.

The installation of the machine can now be completed. Before putting the machine into use the complete system (i.e. the machine and all its safeguarding devices) should be commissioned by qualified personnel and as a minimum the commissioning checks described in section 4.1.1 of this manual should be performed.

Periodic checks in accordance with section 4.1.2 should be carried out at the prescribed intervals. Daily checks to be performed on the GS140 system are detailed in section 4.1.3 of this manual. In some cases there are specific statutory requirements concerning the examination, inspection and test of a machine and its safety devices. It is for the user to determine if such requirements exist for the machine in question and to ensure that those requirements are met.

4. PERIODIC CHECKING, SERVICING AND MAINTENANCE

4.1 PERIODIC CHECKING

4.1.1 COMMISSIONING CHECKS

The commissioning examination should be carried out by persons who are competent and who possess all the information supplied with the machine and its safety equipment. The results of the examination should be recorded and copies of this record should be kept by the user and the employer of the person performing the examination. The person carrying out the examination should ensure that the following general standard of performance is met:

(a) It should not be possible for the dangerous parts of the machine to be set in motion while the light curtain is penetrated.

(b) Penetration of the light curtain during a dangerous phase of the operation of the machine should result in the dangerous parts being arrested or, where appropriate, assuming an otherwise safe condition, before any part of a person can reach them. It should not be possible for the dangerous parts to be set in motion until the curtain has been cleared, the safety system has been restored to its normal condition and the machine controls have been re-operated.

The person performing the examination should also:

(c) Inspect the position of the light curtain to ensure that it is set at the correct distance from the dangerous parts of the machine as recorded on the machine information label or plate.

(d) Ensure that additional safeguarding measures have been provided where necessary to prevent access to the dangerous parts of the machine not protected by the sensing unit.

(e) Where appropriate, test the overall system response time using a suitable device and ensure that it is the same or less than that recorded on the machine information label or plate.

(f) Test the detection capability of the sensing unit as described in section 4.1.4 of this manual.

(g) Examine the machine controls and connections to the GS140 system to ensure that the requirements described in this manual and in the machine manual have been met.

(h) Examine the stopping performance monitor (if fitted) to ensure that it is fitted and functioning correctly. Ensure that the means whereby the stopping performance can be assessed by the operator is indicating correctly.

(i) Test the muting arrangements (if fitted).

(j) Examine brakes or clutches (if fitted) as recommended.

NOTE: No stopping performance monitor or muting facility is provided with the basic GS140 system and there is no means provided for the connection of such devices to the system. These devices may however have been provided elsewhere in the machine control system.

4.1.2 6 OR 12 MONTHLY CHECKS

These examinations should be carried out by competent persons. The results should be recorded and a copy kept by the user.

The person should ensure that the general standard of performance as described in section 4.1.1 (a) and (b) is achieved.

The person should perform the commissioning inspections and tests detailed in the section 4.1.1. When checking the stopping performance monitor, item (e), any equally effective means of determining that the overall system response time, as recorded on the machine information label or plate, is not exceeded, is acceptable.

In addition the person should:

(a) Examine all switching elements in the switching paths controlled by the light curtain outputs to ensure that they are functioning correctly and are not in need of maintenance and/or replacement.

(b) Inspect the machine to ensure that there are no mechanical or structural aspects which could prevent the machine from stopping or assuming an otherwise safe condition when called upon to do so.

(c) Examine and inspect the machine controls and the connections to the GS140 system to ensure that no modifications have been made which could adversely affect the system and that suitable modifications have been correctly performed and properly recorded.

4.1.3 DAILY/SETTING EXAMINATION

The following tests should be carried out daily and after setting by a designated person appointed by the machine user. The results should be recorded and a copy should be kept on or near the machine. Specific statutory requirements may apply to certain types of machine. The designated person should:

(a) Check that access to the dangerous parts of the machine is not possible from any direction not protected by the sensing unit and that side and rear guards are in order.

(b) Check that the minimum distance from the dangerous parts of the machinery to the sensing unit is not less than the distance stated on the machine information label or plate.

(c) Check that it is not possible for a person to stand between the dangerous parts of the machine and the sensing unit.

(d) Check that when the muting facility (if fitted) is operative the moving parts are no longer dangerous.

(e) Check that the stopping performance monitor (if fitted) is in use and is set up and functioning correctly.

(f) Check that electrical enclosures are closed and locked and that any keys have been removed for retention by a designated person.

(g) Check for external signs of damage to equipment or to electrical wiring.

(h) Check the detection capability of the GS140 as described in section 4.1.4

4.1.4 CHECKING DETECTION CAPABILITY

The detection capability of the light curtain should be checked as required in the previous sections using the method described below and as shown in Figure 24.

4.1.4.1 GS140 SYSTEM

(a) With power applied to the GS140 system and with the machine at rest, check that the light curtain is functioning by observing the state of the appropriate indicators. The green indicator should be on, the red indicator should be off.

(b) Insert the test piece provided into the curtain with the axis of the test piece perpendicular to the plane of the curtain. Starting at the top of the emitter unit with the test piece less than 150 millimetres from the front of the emitter unit, pass the test piece slowly down the front of the emitter unit. While the full diameter of the test piece is within the area defined by the two arrow markers on the front window, the green indicator should GO OFF AND REMAIN OFF and the red indicator should BE LIT AND REMAIN LIT.

(c) Repeat the above test with the test piece inserted close to the front of the receiver unit and with the test piece inserted at the midpoint between the emitter and receiver units. The indicators should behave as described previously whenever the test piece is between the arrow markers.

WARNING

At no time while the test piece is obstructing the curtain should the green indicator come on. If it does the machine must be isolated and must not be used until the cause has been investigated.

(d) If the system passes the above tests proceed as follows. Initiate a cycle of the machine and then insert the test piece into the curtain. Upon insertion of the test piece during dangerous motion, the dangerous parts should come to rest without apparent delay.

WARNING

If the machine does not stop or there is any delay in its response the machine must be isolated and must not be used until the fault has been rectified.

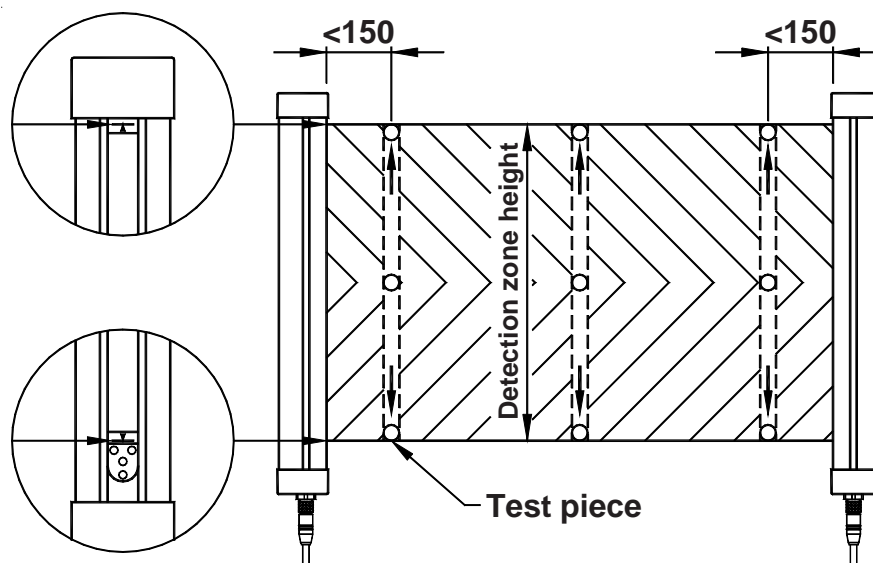

Figure 24

4.1.4.2 GS140 MULTI-BEAM SYSTEM

The operation of the light curtain should be checked as required in the previous sections using the method described below and as shown in Figure 25.

(a) With power applied to the GS140 system and with the machine at rest, check that the light curtain is functioning by observing the state of the appropriate indicators. The green indicator should be on, the red indicator should be off.

(b) To test the curtain is operating correctly, insert your hand in between the emitter and receiver units and obstruct one of the beams, see Figure 18. While the beam is obstructed, the green indicator should GO OFF AND REMAIN OFF and the red indicator should BE LIT AND REMAIN LIT. Move your hand in and out of the beam several times and check that the indicators change state each time as appropriate.

(c) Repeat the above test for each of the beams. The indicators should behave as described above whenever the beams are obstructed.

WARNING

At no time while a beam is obstructed should the green indicator come on. If it does the machine must be isolated and must not be used until the cause has been investigated.

(d) If the system passes the above tests proceed as follows. Initiate a cycle of the machine and then insert your hand into the curtain. Upon insertion of your hand during dangerous motion, the dangerous parts should come to rest without apparent delay.

WARNING

If the machine does not stop or there is any delay in its response the machine must be isolated and must not be used until the fault has been rectified.

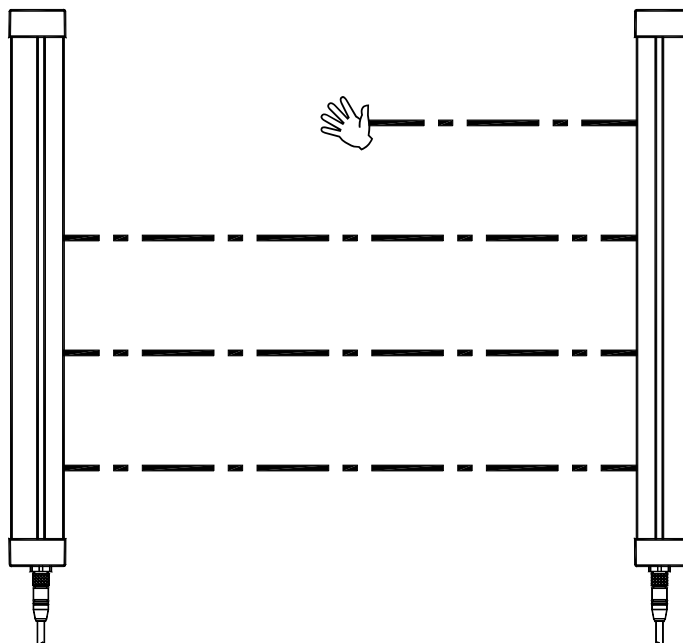

Figure 25

4.2 SERVICING

The GS140 system is designed to be serviced at unit level. There are no user serviceable parts within the units.

When a safety-critical fault occurs in the GS140 system or in the machine interface, the machine will be disabled. It is first necessary to establish whether the fault is in the GS140 system or in the machine interface.

If you require any assistance with the installation or maintenance of your GS140 light curtain, please contact your Guardscan authorised distributor.

4.3 MAINTENANCE

There are no mechanical, electrical or optical adjustments necessary. Apart from occasionally cleaning the windows of the emitter and receiver units, GS140 systems are maintenance free. Use a soft, lint-free cloth and an anti-static cleaner.

Do not use solvents of any kind.

5. TECHNICAL SPECIFICATION

5.1 GS140 LIGHT CURTAIN SYSTEM

Light curtain & Multi-beam systems	S	Stand alone unit
	M	Master unit
	A	Auxiliary slave unit
	D	Double-ended slave unit
Light curtain & Multi-beam systems Operating range	Detection	Range
	14mm	0.5m to 6m
	30mm	0.5m to 15m
	70mm	0.5m to 15m
	2 beam	0.5m to 15m
	3 beam	0.5m to 15m
	4 beam	0.5m to 15m
Light curtain systems Nominal Curtain Length	14mm	200 to 1200mm
	30mm	200 to 1800mm
	70mm	600 to 1800mm
Multi-beam systems Beam spacing	2 beam	500mm
	3 beam	400mm
	4 beam	300mm
Detection capability of light curtains		14mm, 30mm or 70mm
Number of beams in multi-beam systems		2, 3 or 4
Effective aperture angle		$\pm 2\frac{1}{2}^{\circ}$
Response time	14mm detection	20ms upto 300mm curtain. Additional 4ms for each 100mm of curtain
	30mm detection	20ms upto 600mm curtain. Additional 4ms for each 200mm of curtain
	70mm detection	20ms upto 1800mm curtain. Additional 4ms for each 600mm of curtain
	Multi-beam	20ms
Supply voltage		24V d.c. $\pm 20\%$, 5% maximum residual ripple
Power consumption		< 12VA
Enclosure rating		IP65
Radiation wavelength	Wavelength	880nm
	Intensity	Class 1 LED product (IEC60825-1)
Safety output type	Type	Solid state PNP
	Capacity	0,2A
	Voltage	Supply voltage minus 2V
	Max load resistance	<4K ohms
	Max load capacitance	<2.2uF
Standards Applied		EN 61496 4 (self-monitoring) EN 61508-1: 2002 Sil 3 EN 62061:2005 Sil 3 EN 13849-1:2006 PLE
Operating temperature		0°...50° C
Storage temperature		-20°...70° C
Humidity		15% to 95% non-condensing
Weight (each unit)		0,3kg plus 0,2kg per 100mm of curtain
Dimensions - cross section		36 x 45 mm

Table 3

5.2 ORDER CODES AND MODEL NUMBERS

5.2.1 GS140 LIGHT CURTAIN ORDER CODE

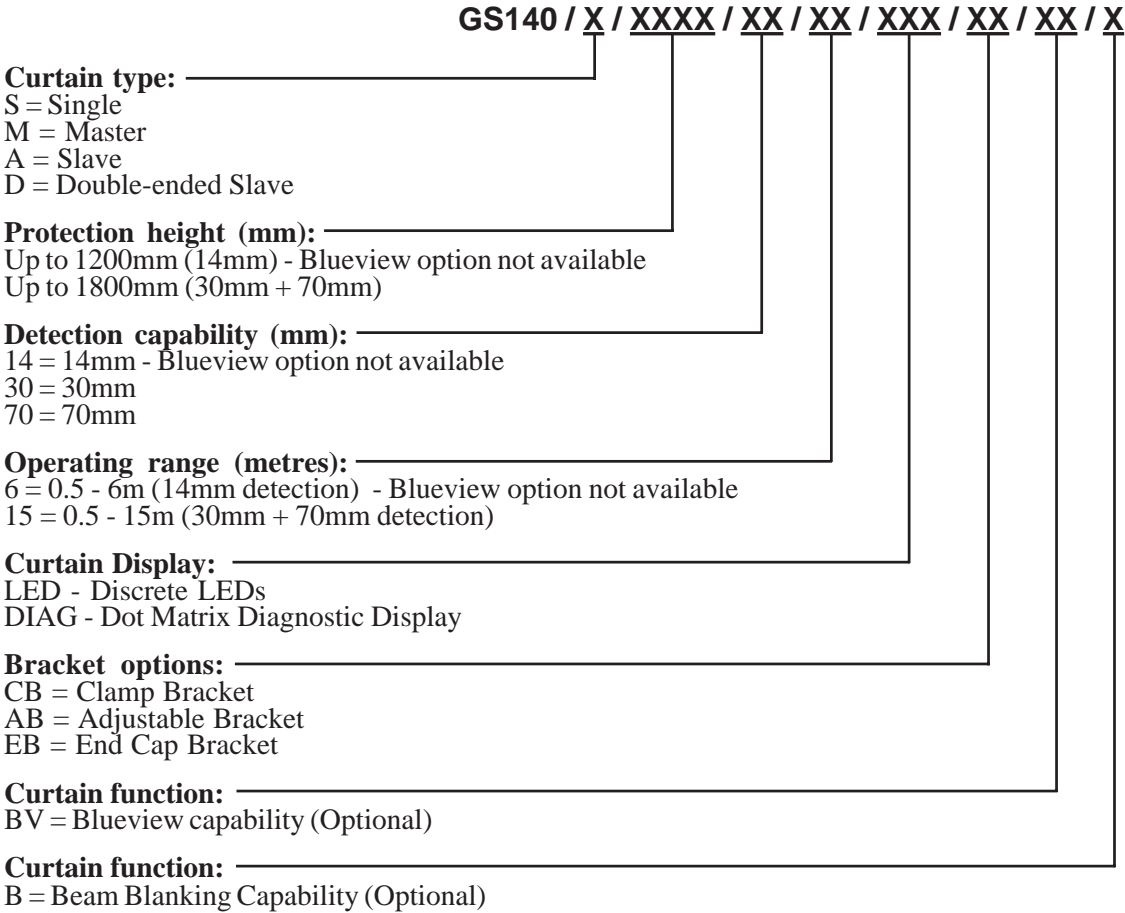

5.2.2 GS140 MULTI BEAM ORDER CODE

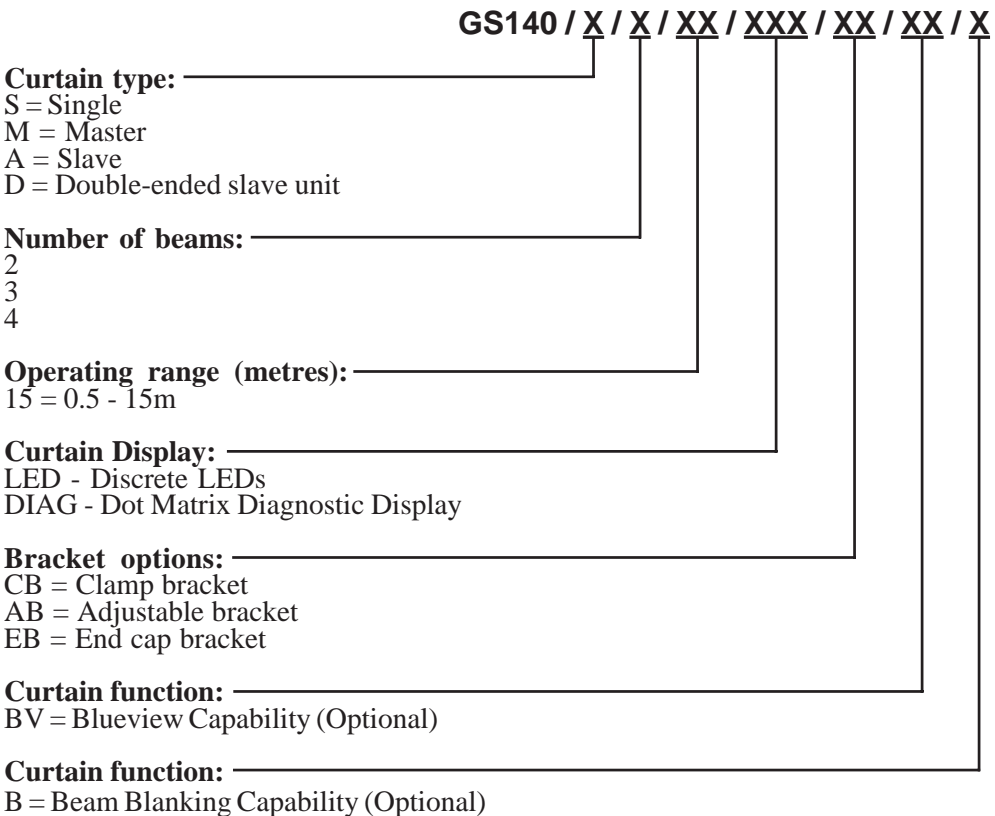

5.2.3 GS140 CONNECTOR CABLE OPTIONS

GS140 connector cable options are available as listed below:

Emitter cable connector (5 way)	5m
Emitter cable connector (5 way)	10m
Emitter cable connector (5 way)	20m
Receiver cable connector (8 way)	5m
Receiver cable connector (8 way)	10m
Receiver cable connector (8 way)	20m
Slave connector cable	0.3m