

MIRROR UNIT & FLOOR POST INSTALLATION INSTRUCTIONS

1. GENERAL

Guardscan mirror units can be used in conjunction with a light curtain to provide efficient and cost effective protection of a dangerous area. The use of mirrors increases the flexibility of a light curtain with the beams being deflected around corners to give two and three sided guard configurations. Guardscan mirror units incorporate a 'T' slot at the back of the mirror allowing for height adjustment if required.

Guardscan floor posts are available for situations where the mirrors or light curtains cannot be mounted to a machine or wall.

The nominal range of the light curtain using these mirror units will be reduced. Each mirror unit will reduce the total operating range by 15-20%.

2. PRODUCT DESCRIPTION

2.1 MIRROR UNITS

The dimensions of the mirror units are shown in Figure 1 and Table 1. The mirror height given in the table is the reflective height. The actual height of the mirror unit is an extra 24mm.

| TYPE | MIRROR HEIGHT |
|-----------|---------------|
| MIRG 365 | 365mm |
| MIRG 685 | 685mm |
| MIRG 1005 | 1005mm |
| MIRG 1325 | 1325mm |
| MIRG 1645 | 1645mm |

Table 1

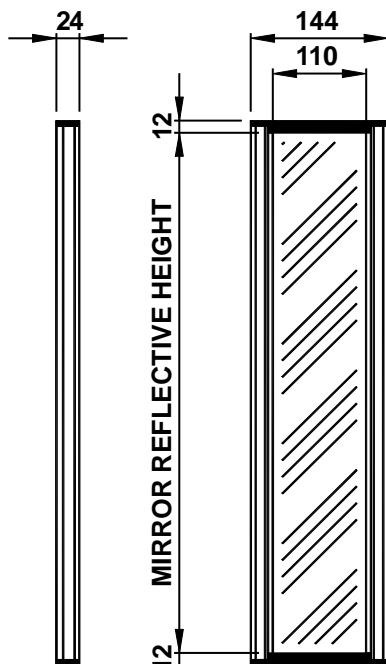

Figure 1

Each mirror unit is supplied with mirror mounting brackets, sliding nuts, washers and screws which locate in the extruded 'T' slots at the back of the unit. See Figure 2.

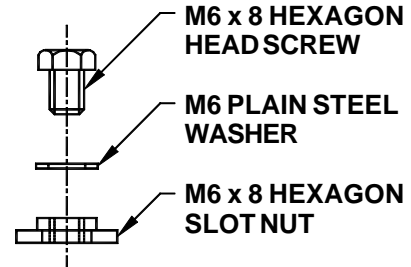

Figure 2

2.2 FLOOR POSTS

There are two types of floor post available, a square floor post, and a range of circular floor posts as shown in Table 2.

2.2.1 SQUARE FLOOR POST

The floor posts are 1200mm in length and are made up of an 80mm square steel post with a substantial square base which can be screwed to the floor. The square floor posts are fully adjustable either for angular rotation or tilt. See Figure 3.

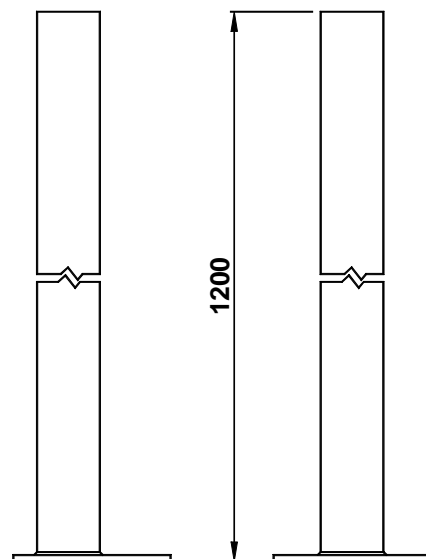
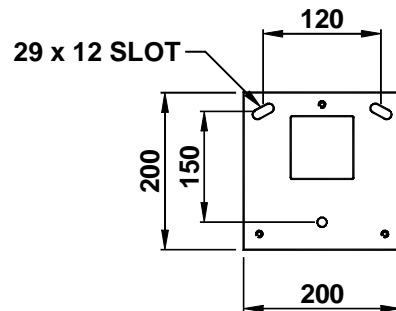

Figure 3

2.2.2 CIRCULAR FLOOR POST

These are made up of a circular post with a triangular base which can be screwed to the floor. They are available in a range of lengths. See Table 2 and Figure 4.

| TYPE | POST HEIGHT |
|-----------|-------------|
| MIRC 385 | 385mm |
| MIRC 705 | 705mm |
| MIRC 1025 | 1025mm |
| MIRC 1345 | 1345mm |

Table 2

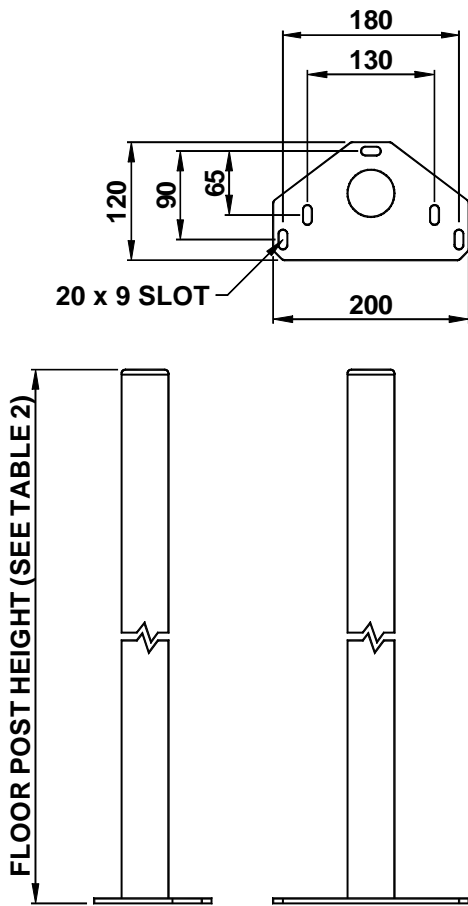

Figure 4

3. INSTALLATION

3.1 GENERAL

Install the light curtains and the mirror units in the required position. It must be possible to adjust them vertically. During mirror unit installation, alignment problems can arise. If you should encounter problems, consider the following:

- a) Ensure the perimeter length does not exceed the maximum operating range, allowing for the reduction previously stated.
- b) Ensure that the emitter unit, the receiver unit, and any mirror units are level both horizontally and vertically.

3.2 MIRROR UNIT WITH SQUARE FLOOR POST

- 1) Secure the two fabricated mirror mounting brackets to each mirror unit using the special sliding nuts, washers and screws provided. See Figure 5 and Figure 6.
- 2) Mark the positions on the side of the floor post where the mirror unit is to be located. See Figure 5 and Figure 6.

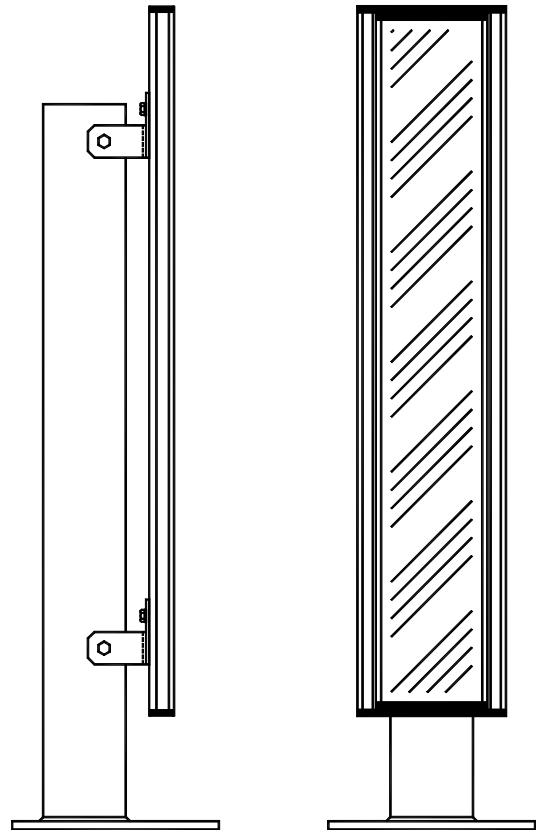

Figure 5

- 3) Secure the mirror mounting brackets to the floor post as follows:
 - a) Drill clearance holes (M6) right through the floor post and secure the brackets in place with M6 x 95mm long screws, washers and nuts.
 - or
 - b) Drill holes 5mm diameter through each side face of the floor post and tap M6. Secure the brackets in place with M6 x 15mm screws. See Figure 5 and Figure 6.
- 4) Finally secure the mirror mounting brackets to the floor post by tightening the fixing screws.

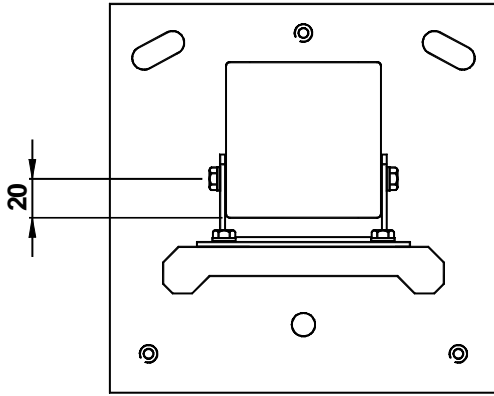

Figure 6

5) If any adjustment of the floor post is required this may be achieved as follows:

a) Rotational/ angular adjustment - slacken the securing screws A & B, rotate the floor post around axis A until alignment is achieved and then fully tighten all securing screws. See Figure 7.

b) Tilt adjustment- slacken the securing screws A & B and adjust the jacking screws C until correct alignment is achieved. Fully tighten securing screws A & B. See Figure 7.

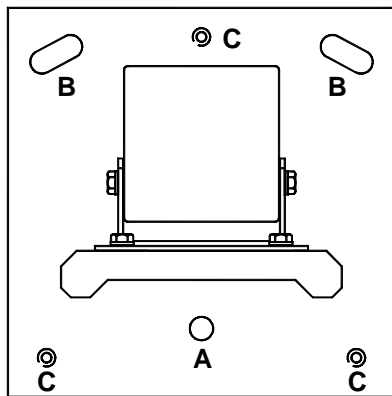

Figure 7

3.3 MIRROR UNIT WITH CIRCULAR FLOOR POST

1) Secure the four L-shaped mirror mounting brackets to each mirror unit using the special sliding nuts, washers and screws provided. See Figure 8.

2) Mark the positions on the floor post where the mirror unit is to be located.

3) Secure the L-shaped mirror mounting brackets to the floor post as follows:

Drill clearance holes (M6) right through the floor post and secure the brackets in place with M6 x 60mm long screws, washers and nuts provided.

4) Finally secure the mirror mounting brackets to the floor post by tightening the fixing screws.

5) Rotational adjustment can be achieved by rotating the floor post on the mounting slots on the base.

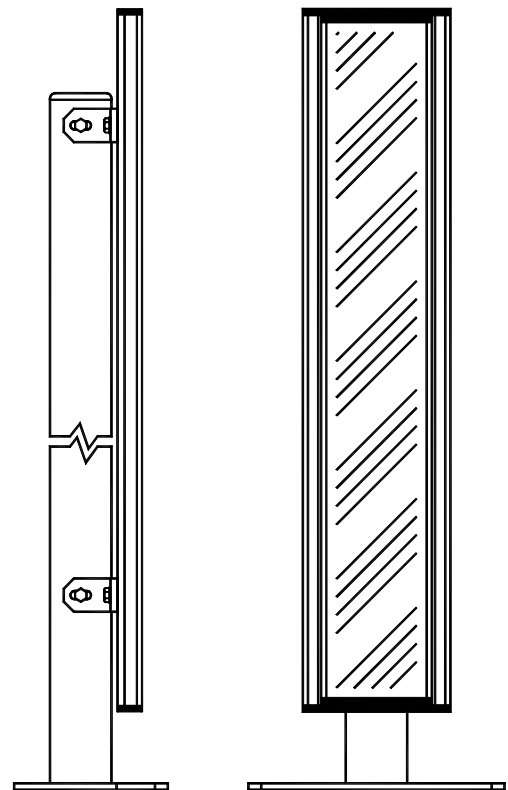
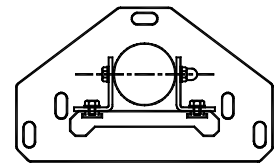

Figure 8

3.4 OPTICAL ALIGNMENT

Mirrors are ideal for area guarding because they provide economical protection for guarding in two or three sided applications.

Having correctly installed the light curtain and the mirror units, to ensure alignment it is necessary to proceed as per the following instructions:

3.4.1 TWO SIDED APPLICATION (FIGURE 9)

1) Stand behind the emitter unit looking toward the mirror / floor post and have someone rotate the mirror unit until the receiver unit is visible and centered in the mirror.

The Guardscan LA-SE laser alignment tool is available to assist in accurately aligning the system.

2) Connect the emitter unit and the receiver unit to the control unit as shown in the appropriate manual and apply the appropriate power to the control unit.

3) Adjust the emitter unit and the receiver unit until the green LED on the receiver unit is ON. When this condition is obtained, it is necessary to find the 'mid-point' of alignment to ensure that vibration does not interfere with the system.

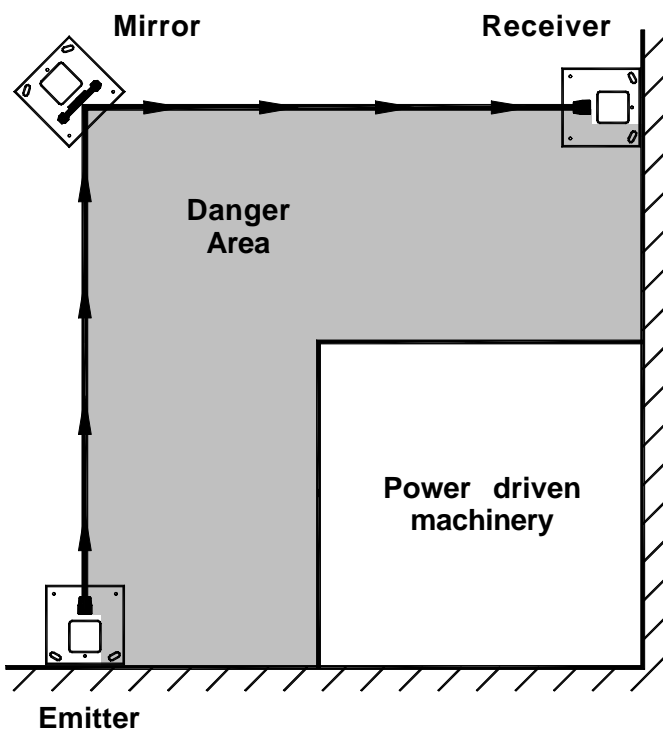

Figure 9 - 'L' shaped protection (when the curtain protects two sides with the addition of one mirror unit).

3.4.2 THREE SIDED APPLICATION (FIGURE 10)

1) Measure the required distance from the emitter unit and the receiver unit to the required position of the mirrors.

2) Locate the mirror units in a straight line from the emitter unit and from the receiver unit so that the mirror surface is perpendicular to the vertical centerline of each sensing unit. Measure the distance from the vertical centerline of one mirror unit to the other and adjust them to a distance equal to that between the vertical centre lines of the emitter and receiver units.

3) Slowly pivot one mirror unit then the other, towards each other so that the mirror face is at approximately a 45° angle to the vertical centre line of the emitter or receiver unit.

4) Level the emitter unit, the receiver unit and both mirror units, adjusting as necessary, making sure that all beams are centered vertically within the mirrors.

5) Stand behind the emitter unit looking in a straight line out to the first mirror unit. The receiver unit should be visible in the mirror. If not, slightly rotate each mirror unit until the receiver unit is visible and centered in the mirror. Repeat the same procedure from behind the receiver unit.

The Guardscan LA-SE laser alignment tool is available to assist in accurately aligning the system.

6) When properly aligned, the red LED on the receiver unit will change to green switching the output relays.

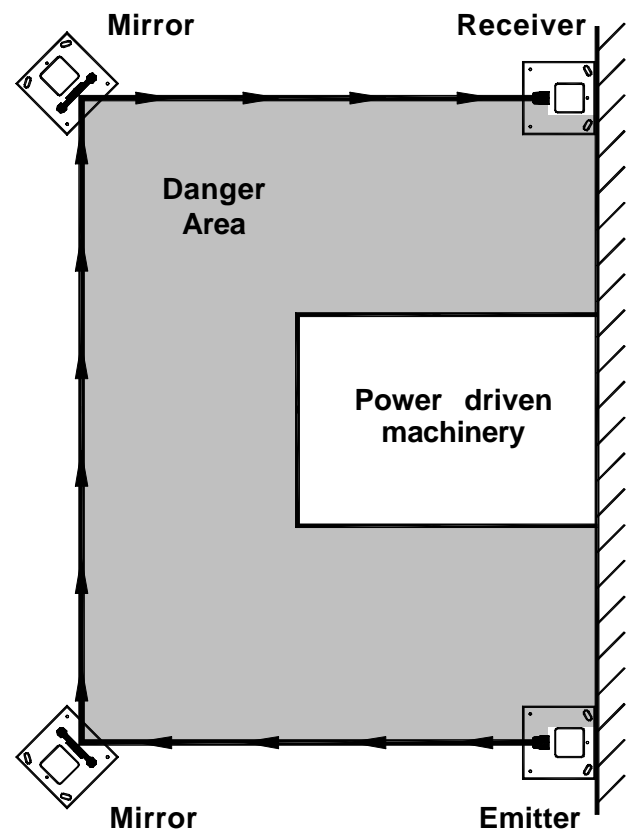

Figure 10 - 'U' shaped protection (when the curtain protects three sides with the addition of two mirror units).