



TAPESWITCH CONTROL UNIT TYPE PSSR/2 INSTALLATION INSTRUCTIONS

1. INTRODUCTION

Tapeswitch PSSR/2 control units are designed to be used with Tapeswitch pressure sensitive sensors to form a complete safety system. The control unit can be configured to monitor one or two sensors. Sensors may take the form of safety mats, sensing edges, ribbon switches or bumpers. Full system installation instructions are supplied with the sensors.

2. PRODUCT DESCRIPTION

The unit operates from a 24V a.c./d.c. supply. From this is derived a current limited 24V d.c. supply. The sensor and control circuit operate from this current-limited supply. The unit is housed in a DIN rail mounting enclosure with 14 integral terminals. This unit is intended to be mounted in an existing electrical enclosure on the machine. This existing enclosure must be sealed to minimum rating of IP54.

3. SAFETY INTEGRITY

Tapeswitch PSSR/2 control units meet the requirements of Performance Level PLd as defined in EN13849-1:2008. The control units are self-monitoring which means that any faults in safety critical components will be detected and will render the machine inoperative until the fault is rectified. However, the safety integrity of the system as a whole depends on the safety integrity of the sensor used. See information supplied with sensor for further details.

4. PRINCIPLE OF OPERATION

The control unit contains the power supply for the system, the safety output relays and the reset circuit. Figure 1 shows the principle of operation. The sensor(s) incorporates a 6K8 end-of-line resistor and the output relays are only energised when this resistance is detected. The output contacts of the safety relays are only closed when the output relays are energised. When the sensor is actuated, the EOL resistor is short-circuited this changed in resistance is detected by the control unit causing the output relays to de-energise. Furthermore, if the power supply to the control unit is interrupted or there is a fault in the sensor wiring or in the switch elements, the relays will de-energise and the output contacts will open. The unit provides a manual or auto reset function selectable using internal switch SW2. In manual reset mode the reset function provides start and restart functions as follows:

START FUNCTION - When power is applied to the system, the output relays cannot be energised until a reset signal has been applied.

RESTART FUNCTION - Once the sensor has been actuated and the output relays have de-energised, they cannot be energised again until a reset signal has been applied.

In auto reset mode the output relays will be energised whenever power is applied to the system and the sensor is clear.

In manual or auto reset mode reset will be prevented while the sensor is actuated, if there is a fault in the reset input circuit or if the two output relays are in disparity.

The safety output contacts of the control unit must be connected to the machine primary control element(s) in such a way that if either of the safety output relays is de-energised then the machine will be brought to rest regardless of the state of the other relay. **NOTE:** A machine primary control element or MPCE is defined as 'an electrically controlled element which directly controls the normal operating motion of a machine such that it is the last (in time) to operate when motion is initiated or arrested'. In addition, where the machine control system has two MPCE's, these devices can be monitored by connecting normally closed auxiliary contacts from each MPCE in series with the reset input. Disparity between the two MPCE's will prevent a reset.

5. MONITOR OUTPUT

The monitor output is a normally-closed volt-free relay output. The monitor relay is energised when the safety output relays are energised. The monitor output can be used as an input to a machine control device such as a programmable logic controller (PLC) to signal that the sensor has been actuated.

NOTE: The monitor output is not a safety output and must not be used in the machine stop circuit.

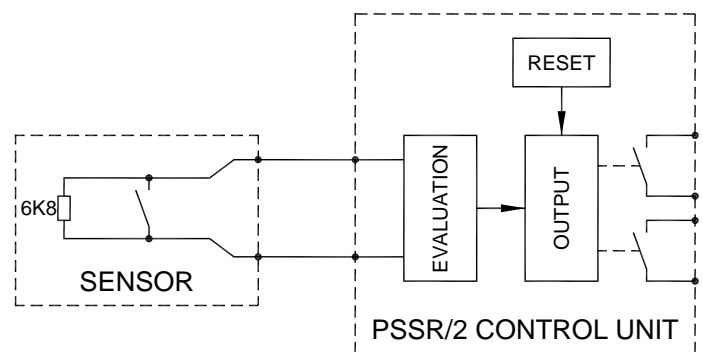

Figure 1 - Principle of Operation

6. INSTALLATION

WARNING

TAPESWITCH SAFETY SYSTEMS ARE DESIGNED TO PROTECT OPERATORS WORKING AT OR NEAR DANGEROUS MACHINES. THEY CAN ONLY PERFORM THAT FUNCTION IF THEY ARE CORRECTLY FITTED AND INTERFACED TO A SUITABLE MACHINE. EVERY EFFORT HAS BEEN MADE TO PROVIDE COMPREHENSIVE AND ACCURATE INFORMATION. IT IS THE RESPONSIBILITY OF THE USER TO ENSURE THAT ALL PERSONS INVOLVED IN THE INSTALLATION OF THE PRODUCT HAVE THE KNOWLEDGE, TRAINING AND EXPERIENCE NECESSARY AND THAT THEY ARE FULLY CONVERSANT WITH ALL LAWS, RULES, REGULATIONS AND CODES OF PRACTICE PERTAINING TO THEIR TASK.

6.1 MECHANICAL

6.1.1 GENERAL

The PSSR/2 control units should be mounted in the machine control unit on standard 'top hat' terminal rail type DIN EN 50 022-35. The machine control unit must provide sealing to IP54 according to IEC 529. The dimensions of the unit are shown in Figure 2. The exact cabling requirements are at the discretion of the installer and depend to a large extent on the siting of the various control system elements. Generally it is recommended that high voltage cables are routed away from low voltage cables.

6.1.2. RESET SWITCH

A momentary action, normally-open switch, preferably a 22mm industrial pushbutton, should be used to provide the reset input. The switch should be housed in a suitable enclosure and should be mounted in such a position that it is safe from damage by passing traffic and such that the person operating the switch can see all of the dangerous area.

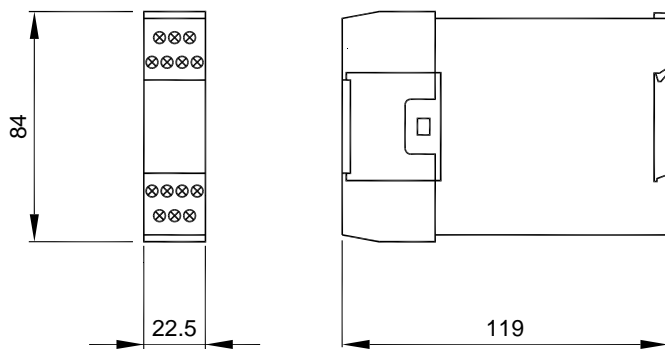

Figure 2 - PSSR/2 Dimensions

6.2 ELECTRICAL

6.2.1 GENERAL

The connections for the PSSR/2 control unit are shown in Figure 3. Crimped ferrules should be fitted on all stranded wires. It is recommended that electrical installation is performed in the order described below.

6.2.2 SENSOR CONNECTION

Select one or two sensor operation using internal switch SW1 as shown in Figure 4. Access to the internal switch is gained by using a screwdriver to gently prise upwards the central lid. Connect the sensor cables to the control unit according to Table 1, taking particular care that there are no stray strands which could cause a short between adjacent terminals.

6.2.3 RESET INPUT CONNECTION

For auto reset mode set internal switch SW2, as shown in Figure 5, and connect a link across terminals X1 and X2, as shown in Figure 6. For manual reset mode set internal switch SW2, as shown in Figure 5, and connect a normally-open switch across terminals X1 and X2 as shown in Figure 7.

If the machine has two MPCEs, a pair of normally-closed auxiliary contacts from each MPCE can be connected in series with the reset input as shown in Figure 8. This provides cross-monitoring of the MPCEs such that if they are in disparity due to a fault, reset will be prevented until the fault is rectified.

6.2.4 POWER CONNECTION

Connect +24V to terminal A1 and 0V to terminal A2 as shown in Figure 3. The maximum power consumption is 5VA.

6.2.5 SAFETY OUTPUT CONNECTION

Two normally-open safety outputs are provided. In lower risk applications (Category 2 or lower) the machine is commonly provided with a single MPCE. In such cases both safety outputs should be connected in series with the MPCE coil as shown in Figure 9. If the machine is fitted with two MPCEs (Categories 3 and 4), one safety output should be connected in series with each MPCE coil as shown in Figure 10.

To protect the contacts of the safety output relays from the effects of switching inductive loads, it is recommended that arc suppressors should be fitted in parallel with the MPCE coils as shown Figures 9 and 10. Arc suppressors must not be fitted across the safety relay contacts.

To protect against the possibility of both safety outputs welding in, due to an overcurrent fault in the machine circuit, 2A fuses should be fitted in series with the MPCE coils as shown in Figure 8 and 9. This limits the current through the safety output contacts to well below that which could cause the contacts to weld.

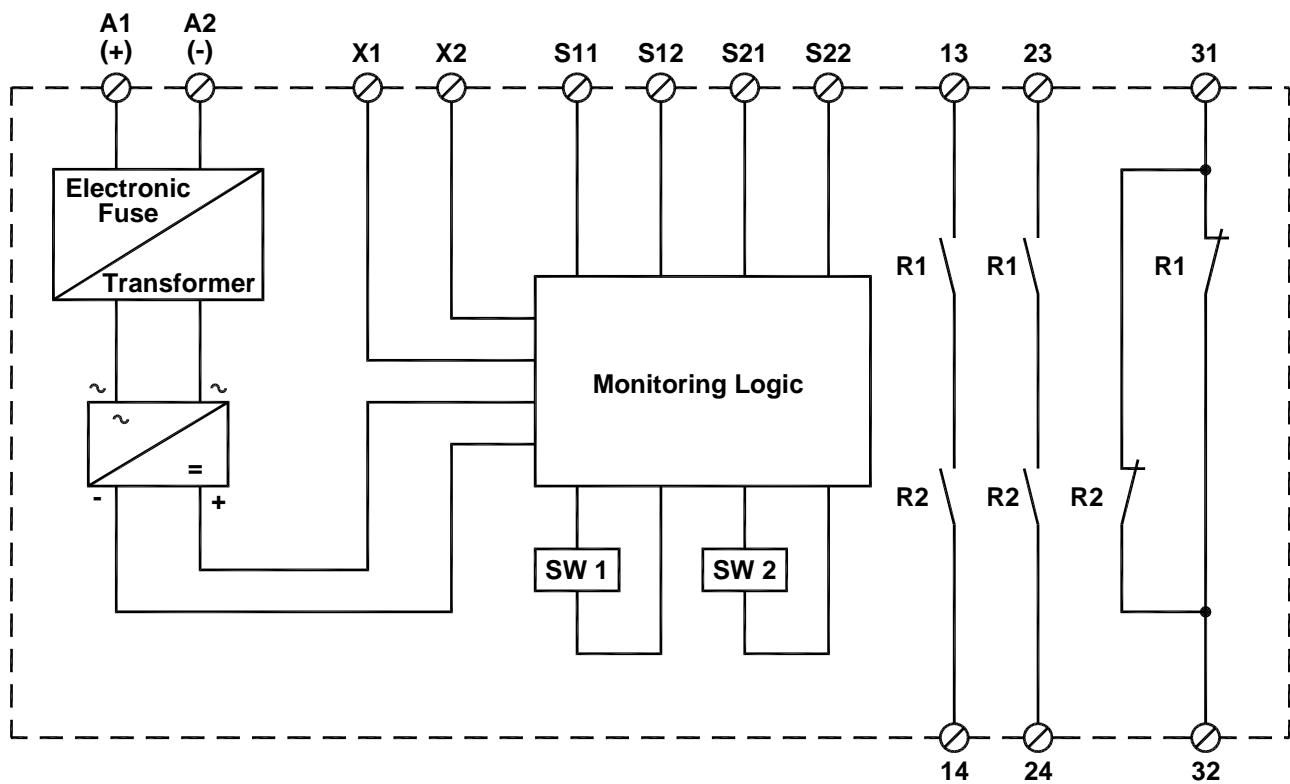

Figure 3 - PSSR/2 Schematic

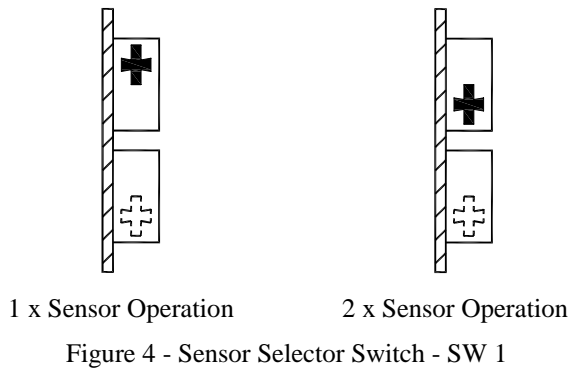

Figure 4 - Sensor Selector Switch - SW 1

SENSOR CONFIG	SENSOR CONNECTION			
	S11	S12	S21	S22
ONE SENSOR	Brown or Ribbed	White or Smooth	Not connected	Not connected
TWO SENSORS	Brown 1 or Ribbed 1	White 1 or Smooth 1	Brown 2 or Smooth 2	White 2 or Smooth 2

Table 1

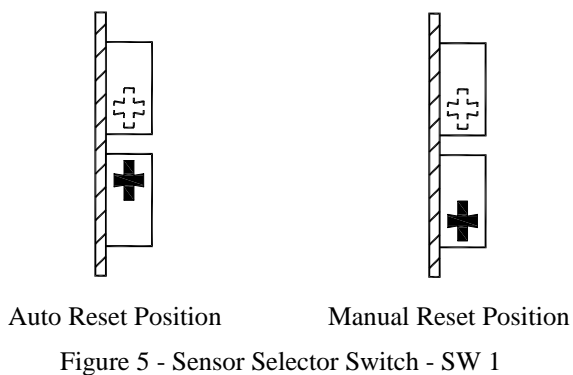

Figure 5 - Sensor Selector Switch - SW 1

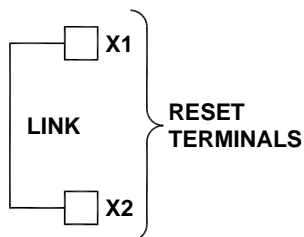

Figure 6 - Auto Reset

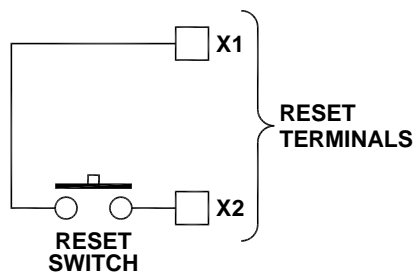

Figure 7 - Manual Reset

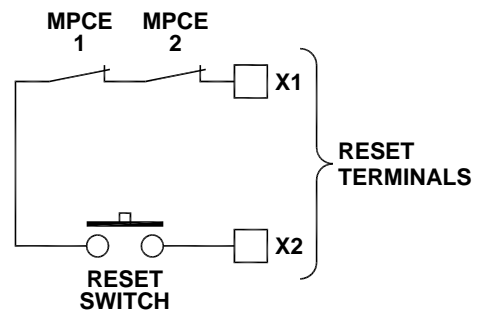

Figure 8 - Manual Reset & MPCE Monitoring

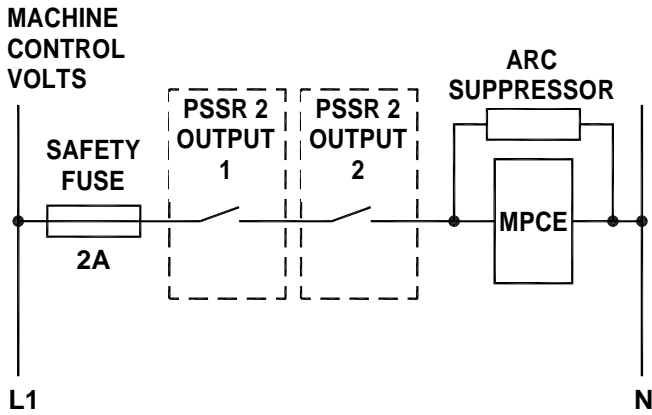

Figure 9 - Safety Output Connection (Single MPCE)

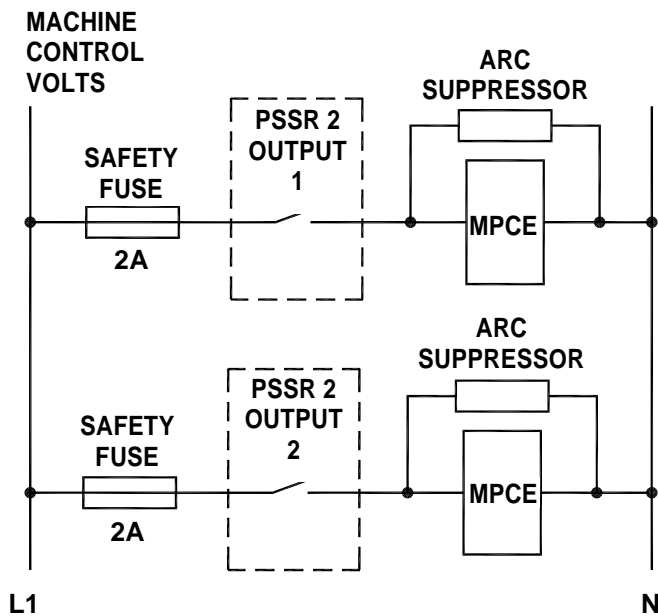

Figure 10 - Safety Output Connection (2 x MPCE's)

6.3 INITIAL CHECKING

The system can be checked at this point as follows:

- (a) Check that the sensor(s) is (are) connected and clear.
- (b) Apply power to the control unit. **DO NOT APPLY POWER TO THE MPCE'S.** The POWER indicator (red) should be lit, the SENS1 and SENS2 indicators (yellow) should both be lit.
- (c) For Auto Reset (where there is a link from X1 to X2), the output relays will be energised and the O/P indicator (green) will be lit.
- (d) For Manual Reset (where there is a momentary action normally-open switch between X1 and X2), press and release the reset button. On release the output relays will be energised and the O/P indicator (green) will be lit.
- (e) Actuate the sensor(s). When a sensor is actuated its indicator be off the output relays should de-energise and the O/P should be off.

If the system operates as described above the installation can be completed. Before putting the machine into use the complete system should be commissioned as described in the sensor manual. If the safety system does not operate as described above refer to the sensor manual for fault finding procedure.

7. TECHNICAL SPECIFICATION

Safety Performance Level	PLd (EN13849-1:2008)
Probability of dangerous failures per hour (PFHd)	1.03×10^{-7}
Power consumption	3VA
Response Time	13ms
Temperature Range	-10C to +55C
Reset Function	Auto or Manual
Supply Voltage	24V ac/dc
Safety Outputs: Device Type	Safety relay Force guided relays
Contacts	2 x normally open 1 x normally closed (monitor)
Rating	5A @ 240Vac
Maximum Sensor Length	100m
Enclosure Protection Rating	IP20

Table 2